

FORM 8904
Supersedes Form 8559
FEBRUARY, 1923

LIST
OF
PARTS



MACHINES
Nos. 42-1 to 42-4 and 42-8

** A TRADE MARK OF
THE SINGER MANUFACTURING COMPANY

From the library of: Diamond Needle Corp

INSTRUCTIONS FOR OILING

To ensure easy running and prevent unnecessary wear of the parts which are in movable contact, the machine requires oiling and when in continuous use, "TYPE B" or "TYPE D" OIL, sold only by Singer Sewing Machine Company, should be applied at least twice each day to all oil holes marked "OIL", as instructed in Form 7919 "TYPE D" OIL is stainless.

COPYRIGHT, U. S. A., 1917, 1918, 1920 AND 1923,
BY THE SINGER MANUFACTURING CO.
ALL RIGHTS RESERVED FOR ALL COUNTRIES

INDEX

	PAGE
ACCESSORIES.....	38
BINDER (ENGLISH).....	39
BINDERS (ADJUSTABLE).....	38
BINDERS ON SHANK.....	39
BOBBIN WINDERS.....	42
CORDERS.....	40
EDGE FOLDER.....	41
FOR COVERING CORD WITH THIN LEATHER.....	40
HEMMERS ON SHANK.....	41
KNEE LIFTER PARTS.....	40
MACHINE NO. 42-1.....	7
" " 42-2.....	13
" " 42-3.....	19
" " 42-4.....	26
" " 42-8.....	32
NUMERICAL LIST OF PARTS.....	55
OBSOLETE PARTS.....	51
PIPING ATTACHMENTS.....	41
PRESSER FOOT.....	41
STAND.....	49
THROAT PLATE.....	41
TRIMMINGS FOR END AND BACK LEAF TABLE.....	50
WELT GAUGE ON SHANK.....	41

From the library of: Diamond Needle Corp

INSTRUCTIONS FOR ORDERING

In ordering from this list, use **ONLY** the **PART** number in the **FIRST** column.

The number stamped on a Sewing Machine part is in **every case** the number of the single part only.

Every combination of parts sent out as such has its specific number, which, although not stamped on the parts, must be used when ordering the combination.

Each number always indicates the **SAME PART** in whatever list it appears, or for whatever machine.

The letters after some of the numbers indicate the style of finish only, as follows:

- A. Hardened, Polished and Plated.
- B. Polished and Plated.
- C. Hardened only.
- D. Polished only.
- E. Soft, hot Polished.
- F. Hardened and Polished.
- G.
- H. Blued.
- J. Plated only.
- K. Hardened and Plated.
- L. Brass or Gilt
- M. Oxidized.
- P. Japanned.
- R. Parkerized.

These letters **MUST BE USED** when they appear in the list, and **AFTER** the number as in the list.

In this series

1 to 1500 and 50001 to 51500 are Screw Numbers.

1501 to 1800 are Nut Numbers.

1801 to 2000 are Roller Numbers.

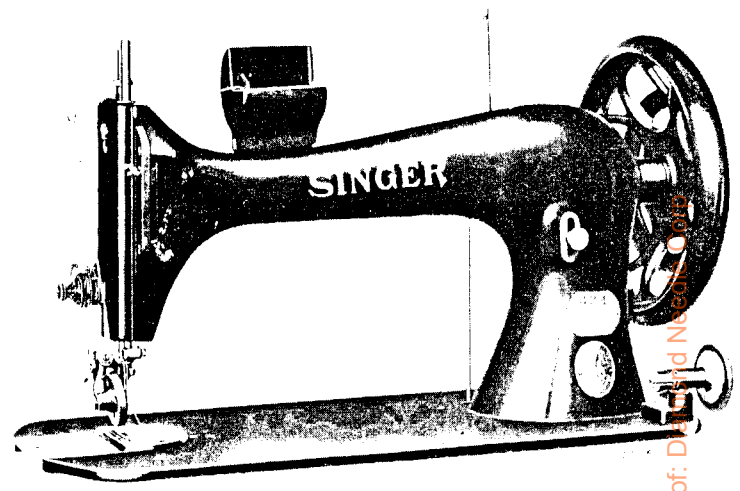
2001 to 50000 and 52001 and upward are numbers of Machine Parts.

The figures in the second column refer only to the plates illustrating the parts, and are **NOT TO BE USED** in ordering.

Parts marked with an asterisk (*) are furnished only when repairs are made at factory.

LIST OF PARTS COMPLETE

FOR



MACHINE No. 42-1

FOR LEATHER. C. B., CAM ON NEEDLE BAR, DROP FEED
 AT LEFT OF NEEDLE, ROLLER PRESSER, BOBBIN NO.
 5810. BALANCE WHEEL (TWO SPEED) NO. 3011.
 DIAMETER OF BELT GROOVES 3 AND 5 INCHES.

NO.	PLATE	NAME
*5453	---	Arm with 4448 and 4449
2002	686	" Dowel Pin
4448	695	" Oil Tube for intermediate bearing
	123E	691 " Screw
6109	696	" Shaft for 3011
6107	696	" " " 5977
3005	678	" " Bushing (back)
448C	691	" " " Set Screw
*4449	---	" " " (front)
144D	691	" " Screw
4288	678	" Side Cover
	286D	692 " " " Thumb Screw
5811	695	" Spool Pin and Thread Eyelet
8879	7801	" " " Washer (cloth)

From the library of: David N. ...

NO.	PLATE	NAME
3011	696	Balance Wheel (two speed) 3 in. and 5 in. pulleys, with two 448c, for 6109.....
5977	696	Balance Wheel (two speed) for 5981.....
448c	691	" " Set Screw.....
*5900	—	Bed with two 3016 and six 3021.....
3016	679	Bed Hinge complete, Nos. 3017, 3018 and 3020.....
3017	—	Bed Hinge (half butt) for 5900.....
3018	—	" " " " " wood table.....
3020	683	" " Pin.....
3021	686	" " Rivet.....
5969	3642	Crank Connecting Rod with 4349 and two 158E.....
*4349	—	Crank Connecting Rod Cap.....
158E	691	" " " " Screw.....
566c	692	" " " Hinge Screw.....
1513J	693	" " " " " Nut.....
5978	696	Driving Flange with two 435c.....
5979	683	" " Latch.....
136F	691	" " Hinge Screw.....
435c	691	" " Set Screw.....
5980	683	" " Spring.....
330D	692	" " " Screw.....
5993	—	Driving Flange complete, Nos. 136F, 330D and 5978 to 5980.....
5808	696	Face Plate.....
8177	—	" " 5808 with 2105.....
8180	—	Face Plate complete, Nos. 448c, 2107, 2127, 5797, 5989, 5991, 8177 and two 233D.....
164D	691	Face Plate Screw.....
2107	686	" " Thread Guard.....
233D	691	" " " " Screw.....
5902	677	Feed Bar.....
313c	692	" " Screw Centre.....
1519J	693	" " " " Nut.....
3032	678	" Cam with 446c.....
446c	691	" " Set Screw.....
3033	681	" Connecting Link.....
375c	692	" " " Hinge Screw.....
1518E	693	" " " " " Nut.....
5800	687	" Dog, for leather, 20 teeth.....
5904	687	" " " " work, 12 teeth.....

NOTE: No. 5904 is sent with this machine unless another Feed Dog is specified on order.

NO.	PLATE	NAME
191c	691	Feed Dog Screw.....
5907	3642	" Forked Connection.....
375c	692	" " " Hinge Screw.....
1518E	693	" " " " " Nut.....
5908	3642	" Lifting Rock Shaft.....
5909	—	Feed Lifting Rock Shaft complete, Nos. 3166 and 5908.....
3166	682	Feed Lifting Rock Shaft Crank with 157J and 1813.....
157J	691	Feed Lifting Rock Shaft Crank Clamping Screw.....
1813	693	Feed Lifting Rock Shaft Crank Roller and Stud.....
304c	692	Feed Lifting Rock Shaft Screw Centre.....
1513J	693	" " " " " Nut.....
3039	684	" Regulator.....
1128E	3643	" " Hinge Screw.....
818D	692	" " Thumb Screw.....
5910	3642	" Rock Shaft.....
5911	—	Feed Rock Shaft complete, Nos. 5910 and 5913.....
5913	682	Feed Rock Shaft Crank with 453c.....
2049	686	" " " " Pin.....
453c	692	" " " " Set Screw.....
304c	692	" " " Screw Centre.....
1513J	693	" " " " " Nut.....
25867	7795	Guide.....
747D	3644	" Thumb Screw.....
5981	—	Loose Wheel Attachment complete, Nos. 5977 and 5993.....
5465	678	Needle Bar.....
5457	681	" " Cam with two 175E.....
175E	691	" " " Clamping Screw.....
5458	681	" " " Guide.....
178c	691	" " " " Screw.....
1860	693	" " " Roller and Stud.....
453c	692	" " " " " " " S e t Screw.....
290E	692	Needle Bar Screw Bushing.....
4803	686	Needle Clamp complete, Nos. 651D, 808F and 4802.....
808F	691	Needle Clamp Screw.....
4802	686	" " Thread Guide.....
651D	692	" " " " Screw.....
5778	696	Oil Cup.....
5779	695	" " Pad (felt).....
211D	692	" " " Screw.....

NO.	PLATE	NAME
7071	695	Oil Cup Pad Screw Washer.....
135D	691	" " Screw.....
5780	695	" " Thread Eyelet.....
5781	—	Oil Cup complete, Nos. 211b, 5778 to 5780 and 7071.....
*5970	679	Oscillating Rock Shaft with 11165.....
8163	—	" " " 5970 with 635c, 1513j and 56812.....
3052	678	Oscillating Rock Shaft Hinge Pin.....
56812	—	" " " " " 3052 with 1513j.....
1513j	693	Oscillating Rock Shaft Hinge Pin Nut..
635c	692	" " " " " Screw Bearing.....
1513j	693	Oscillating Rock Shaft Hinge Pin Screw Bearing Nut.....
11165	695	Oscillating Rock Shaft Oil Pad.....
5834	3642	" Shaft.....
5917	682	" " Collar with 453c.....
453c	692	" " " Set Screw.....
5966	—	" " Crank.....
5967	681	Oscillating Shaft Crank complete, Nos. 453c, 1513j, 1885 and 5966.....
2049	686	Oscillating Shaft Crank Pin.....
1885	693	" " " Roller with 190b, 1054c and 5968.....
190b	691	Oscillating Shaft Crank Roller Cap Screw
5968	686	" " " " " " " Washer.....
1054c	3643	Oscillating Shaft Crank Roller Screw Stud
1513j	693	" " " " " " " Nut.....
453c	692	Oscillating Shaft Crank Set Screw.....
3054	678	Presser Bar.....
5990	681	" " Lifter.....
689c	691	" " " Screw.....
1520E	693	" " " Nut.....
5612	678	" " Lifting Bracket with 453c.....
453c	692	" " " " Set Screw.....
290E	692	" " Screw Bushing.....
6466	678	" " Spring.....
2070	686	" " " Washer.....
5971	687	" Foot (long shank).....
190D	691	" " Screw.....
262j	692	Pressure Regulating Thumb Screw.....
1875	—	Roller with 634D and 1528j.....
8152	—	" Arm.....

NO.	PLATE	NAME
440F	691	Roller Arm Adjusting Screw.....
1547j	693	" " " " Nut.....
2206	—	" " Bracket.....
316F	692	" " " " Screw Centre.....
1547j	693	" " " " " Nut.....
2205	695	" " Lock Spring.....
176D	691	" " " " Screw.....
1549j	693	" " " " " Nut.....
634D	692	" Screw.....
1528j	693	" " Nut.....
5964	687	Roller Presser complete, 1½ in. roller, Nos. 176D, 440F, 1549j, 1875, 2205, 2206, 8152, two 316F and three 1547j..
190D	691	Roller Presser Screw.....
5810	684	Shuttle Bobbin (solid).....
5786	684	" " Case Latch.....
5787	684	" " " " Lever.....
5788	684	" " " " " Fulcrum Pin.....
5838	684	Shuttle Bobbin Case Latch Spring.....
592E	692	" " " " Stop Screw...
5785	—	" " " Hinge, Nos. 5786 to 5788.....
5789	684	Shuttle Bobbin Case Position Finger....
5933	684	" " " " " Rivet
5784	684	Shuttle Bobbin Case complete, Nos. 591F, 592E, 5785, 5789, 5838, 5933 and 5935
5934	684	Shuttle Body.....
591F	692	" Tension Regulating Screw.....
5935	684	" " Spring.....
5783	—	Shuttle, 2½ in. diam., Nos. 5784, 5810 and 5934.....
5832	677	Shuttle Driver.....
2049	686	" " Pin.....
5938	677	" Race Back.....
5939	677	" " " Spring.....
741D	691	" " " " Screw.....
5965	686	" " " Steady Pin.....
5973	—	" " Body.....
5942	677	" " Cap.....
219D	691	" " " Screw.....
5943	677	" " Frame with 5944.....
575E	3636	" " " Clamping Screw....
5944	686	" " " Steady Pin.....
5972	677	Shuttle Race complete, Nos. 741D, 5938, 5939, 5942, 5973 and two each 219D and 5965.....

NO.	PLATE	NAME
141D	3636	Shuttle Race Screw.....
5945	—	“ “ Slide.....
5946	677	Shuttle Race Slide complete, Nos. 5945, 5947 and two 725E.....
5947	682	Shuttle Race Slide Spring.....
725E	3636	“ “ “ “ Screw.....
1560c	693	Tension Regulating Thumb Nut.....
817c	693	“ Screw Stud.....
8183	—	“ “ “ 817c with 1560c.....
448c	691	“ “ “ Set Screw.....
2103	685	“ Spring.....
2105	686	“ Thread Guard.....
5983	686	“ Washer (felt).....
5984	686	“ “ (steel).....
5795	686	“ Wheel with 5796.....
*5796	—	“ “ Flange.....
5797	—	Tension complete (wheel) Nos. 2103, 5795, 8183 and two each 5983 and 5984.....
12296	686	Thread Eyelet (side of arm).....
2455	685	“ Retainer Disc.....
1562J	693	“ “ Regulating Thumb Nut.....
418E	693	“ “ Screw Stud.....
10141	685	“ “ Spring.....
5989	—	Thread Retainer complete, Nos. 418E, 1562J, 10141 and two 2455.....
5952	678	Thread Take-up Cam with 446c and 453c.....
3012	683	“ “ “ Pin.....
446c	691	“ “ “ Set Screw.....
*5954	678	“ “ Lever with 1819.....
8161	—	“ “ “ 5954 with 1088c.....
1088c	3636	“ “ “ Hinge Screw.....
1819	693	“ “ “ Roller and Stud.....
5991	686	“ “ Spring.....
2127	686	“ “ “ Regulator Plate.....
233D	691	“ “ “ “ “ “ Screw.....
5896	—	Throat Plate Body.....
5897	3649	“ “ Needle Hole Strip.....
401E	3643	“ “ “ “ “ Screw.....
5898	3649	Throat Plate complete for 5800 and 5904, Nos. 5896, 5897 and two 401E.....
742F	692	Throat Plate Screw.....
5975	3627	Drip Pan (stand) with four wood screws 5/8 in. No. 5.....
5976	—	Drip Pan (power table) with four wood screws 5/8 in. No. 5.....

LIST OF PARTS COMPLETE

FOR

MACHINE No. 42-2

FOR CLOTH. C. B., LINK NEEDLE BAR CONNECTION, DROP
FEED BOTH SIDES OF NEEDLE, HINGED PRESSER FOOT,
BOBBIN NO. 5810. BALANCE WHEEL (TWO SPEED)
NO. 3011. DIAMETER OF BELT GROOVES 3 AND 5
INCHES.

NO.	PLATE	NAME
*4287	—	Arm with 4448 and 4449.....
2002	686	“ Dowel Pin.....
4448	695	“ Oil Tube for intermediate bearing.....
123E	691	“ Screw.....
6109	696	“ Shaft for 3011.....
6107	696	“ “ “ 5977.....
3005	678	“ “ Bushing (back).....
448c	691	“ “ “ “ Set Screw.....
*4449	—	“ “ “ (front).....
144D	691	“ “ Screw.....
4288	678	“ Side Cover.....
286D	692	“ “ “ Thumb Screw.....
5811	695	“ Spool Pin and Thread Eyelet.....
8879	7801	“ “ “ Washer (cloth).....
3011	696	Balance Wheel (two speed) 3 in. and 5 in. pulleys, with two 448c, for 6109.....
5977	696	Balance Wheel (two speed) for 5981.....
448c	691	“ “ Set Screw.....
*5900	—	Bed with two 3016 and six 3021.....
3016	679	Bed Hinge complete, Nos. 3017, 3018 and 3020.....
3017	—	Bed Hinge (half butt) for 5900.....
3018	—	“ “ “ “ “ wood table.....
3020	683	“ “ Pin.....
3021	686	“ “ Rivet.....
5969	3642	Crank Connecting Rod with 4349 and two 158E.....
*4349	—	Crank Connecting Rod Cap.....
158E	691	“ “ “ “ Screw.....
566c	692	“ “ “ Hinge Screw.....
1513J	693	“ “ “ “ “ Nut.....

NO.	PLATE	NAME
5978	696	Driving Flange with two 435c
5979	683	" " Latch
136F	691	" " Hinge Screw
435c	691	" " Set Screw
5980	683	" " Spring
330D	692	" " " Screw
5993	—	Driving Flange complete, Nos. 136F, 330D and 5978 to 5980
5982	696	Face Plate
8173	—	" " 5982 with 2105
8179	—	Face Plate complete, Nos. 448c, 2107, 2127, 5797, 5989, 5991, 8173 and two 233D
164D	691	Face Plate Screw
2107	686	" " Thread Guard
233D	691	" " " " Screw
5902	677	Feed Bar
313c	692	" " Screw Centre
1519J	693	" " " " Nut
3032	678	" Cam with 446c
446c	691	" " Set Screw
3033	681	" Connecting Link
375c	692	" " Hinge Screw
1518E	693	" " " " Nut
5774	689	" Dog, 12 teeth

NOTE: No. 5774 is sent with this machine unless another Feed Dog is specified on order.

5893	7806	Feed Dog, 21 teeth
5776	688	" " for buff wheels
5905	690	" " " tent work
5906	690	" " " canvas work
191c	691	" " Screw
5907	3642	" Forked Connection
375c	692	" " Hinge Screw
1518E	693	" " " " Nut
5908	3642	" Lifting Rock Shaft
5909	—	Feed Lifting Rock Shaft complete, Nos. 3166 and 5908
3166	682	Feed Lifting Rock Shaft Crank with 157J and 1813
157J	691	Feed Lifting Rock Shaft Crank Clamping Screw
1813	693	Feed Lifting Rock Shaft Crank Roller and Stud
304c	692	Feed Lifting Rock Shaft Screw Centre
1513J	693	" " " " " " Nut

NO.	PLATE	NAME
3039	681	Feed Regulator
1128E	3643	" " Hinge Screw
818D	692	" " Thumb Screw
5910	3642	" Rock Shaft
5911	—	Feed Rock Shaft complete, Nos. 5910 and 5913
5913	682	Feed Rock Shaft Crank with 453c
2049	686	" " " " Pin
453c	692	" " " " Set Screw
304c	692	" " " " Screw Centre
1513J	693	" " " " " Nut
25867	7795	Guide
747D	3641	" Thumb Screw
5981	—	Loose Wheel Attachment complete, Nos. 5977 and 5993
5465	678	Needle Bar
*3045	681	" " Connecting Link
56773	—	" " " " 3045 with 2052
377c	692	Needle Bar Connecting Link Hinge Screw
1518E	693	" " " " " " Nut
2052	683	Needle Bar Connecting Stud with 155c
155c	691	" " " " Set Screw
290E	692	" " Screw Bushing
4803	686	Needle Clamp complete, Nos. 651D, 808F and 4802
808F	691	Needle Clamp Screw
4802	686	" " Thread Guide
651D	692	" " " " Screw
5778	696	Oil Cup
5779	695	" " Pad (felt)
211D	692	" " " " Screw
7071	695	" " " " Washer
135D	691	" " " " Screw
5780	695	" " Thread Eyelet
5781	—	Oil Cup complete, Nos. 211D, 5778 to 5780 and 7071
*5970	679	Oscillating Rock Shaft with 11165
8163	—	" " " " 5970 with 635c, 1513J and 56812
3052	678	Oscillating Rock Shaft Hinge Pin
*56812	—	" " " " " " 3052 with 1513J
1513J	693	Oscillating Rock Shaft Hinge Pin Nut

NO.	PLATE	NAME
635c	692	Oscillating Rock Shaft Hinge Pin Screw Bearing.....
1513j	693	Oscillating Rock Shaft Hinge Pin Screw Bearing Nut.....
11165	695	Oscillating Rock Shaft Oil Pad.....
5834	3642	" Shaft.....
5917	682	" " Collar with 453c.....
453c	692	" " " Set Screw.....
5966	---	" " Crank.....
5967	681	Oscillating Shaft Crank complete, Nos. 453c, 1513j, 1885 and 5966.....
2049	686	Oscillating Shaft Crank Pin.....
1885	693	" " " Roller with 1906b, 1054c and 5968.....
190d	691	Oscillating Shaft Crank Roller Cap Screw.....
5968	686	" " " " " " Washer.....
1054c	3643	Oscillating Shaft Crank Roller Screw Stud.....
1513j	693	" " " " " " Nut.....
453c	692	Oscillating Shaft Crank Set Screw.....
3054	678	Presser Bar.....
5990	681	" " Lifter.....
689c	691	" " " Screw.....
1520e	693	" " " " Nut.....
5608	679	" " Lifting Bracket with 453c.....
453c	692	" " " " Set Screw.....
290e	692	" " Screw Bushing.....
3056	678	" " Spring.....
2070	686	" " Washer.....
5920	687	" Foot (solid).....
5922	---	" " Bracket.....
5924	---	" " Plate.....
5923	686	" " " Hinge Pin.....
5921	689	Presser Foot (tinged) complete, Nos. 5922 to 5924.....
NOTE: No 5924 is sent with this machine unless another Presser Foot is specified on order.		
5955	7806	Presser Foot (long shank) for 5774 and 5893.....
190d	691	Presser Foot Screw.....
262j	692	Pressure Regulating Thumb Screw.....
5810	684	Shuttle Bobbin (solid).....
5786	684	" " Case Latch.....
5787	684	" " " " Lever.....

NO.	PLATE	NAME
5788	684	Shuttle Bobbin Case Latch Lever Fulcrum Pin.....
5838	684	Shuttle Bobbin Case Latch Spring.....
592e	692	" " " " Stop Screw.....
5785	---	" " " Hinge, Nos. 5786 to 5788.....
5789	684	Shuttle Bobbin Case Position Finger.....
5933	684	" " " " " Rivet.....
5784	684	Shuttle Bobbin Case complete, Nos. 591e, 592e, 5785, 5789, 5838, 5933 and 5935.....
5934	684	Shuttle Body.....
591e	692	" Tension Regulating Screw.....
5935	684	" " Spring.....
5783	---	Shuttle, 2½ in. diam., Nos. 5784, 5810 and 5934.....
5832	677	Shuttle Driver.....
2049	686	" " Pin.....
5938	677	" Race Back.....
5939	677	" " " Spring.....
741d	691	" " " Screw.....
5965	686	" " " Steady Pin.....
5973	---	" " Body.....
5942	677	" " Cap.....
219d	691	" " " Screw.....
5943	677	" " Frame with 5944.....
575e	3636	" " " Clamping Screw.....
5944	686	" " " Steady Pin.....
5972	677	Shuttle Race complete, Nos. 741d, 5938, 5939, 5942, 5973 and two each 219d and 5965.....
141d	3636	Shuttle Race Screw.....
5945	---	" " Slide.....
5946	677	Shuttle Race Slide complete, Nos. 5945, 5947 and two 725e.....
5947	682	Shuttle Race Slide Spring.....
725e	3636	" " " " Screw.....
1560c	693	Tension Regulating Thumb Nut.....
817c	693	" Screw Stud.....
8183	---	" " " 817c with 1560c.....
448c	691	" " " Set Screw.....
2103	685	" Spring.....
2105	686	" Thread Guard.....
5983	686	" Washer (felt).....
5984	686	" " (steel).....
5795	686	" Wheel with 5796.....
*5796	---	" " Flange.....

NO.	PLATE	NAME
5797	—	Tension complete (wheel) Nos. 2103, 5795, 8183 and two each 5983 and 5984.
12296	686	Thread Eyelet (side of arm).
2455	685	Retainer Disc.
1562J	693	Regulating Thumb Nut.
418E	693	Screw Stud.
10141	685	Spring.
5989	—	Thread Retainer complete, Nos. 418E, 1562J, 10141 and two 2455.
13017	678	Thread Take-up Cam with 448c.
3012	683	Pin.
448c	691	Set Screw.
*5954	678	Lever with 1819.
8161	—	5954 with 1088c.
1088c	3636	Hinge Screw.
1819	693	Roller and Stud.
5991	686	Spring.
2127	686	Regulator Plate.
233b	691	Screw.
5777	688	Throat Plate for 5776.
5950	690	5905.
5951	690	5906.
5849	—	Body for 5851.
5852	—	5851.
5850	3645	Needle Hole Strip for 5851.
5853	3645	5854.
401E	3643	Screw.
5851	3645	Throat Plate complete for 5774 and 5893, Nos. 5849, 5850 and two 401E.

NOTE: No. 5851 is sent with this machine unless another Throat Plate is specified on order.

5854	3645	Throat Plate complete, for carpet mitres, for 5774 and 5893, Nos. 5852, 5853 and two 401E.
742F	692	Throat Plate Screw.
5975	3627	Drip Pan (stand) with four wood screws $\frac{5}{8}$ in. No. 5.
5976	—	Drip Pan (power table) with four wood screws $\frac{5}{8}$ in. No. 5.

LIST OF PARTS COMPLETE

FOR

MACHINE No. 42-3

FOR CLOTH. C. B., LINK NEEDLE BAR CONNECTION, DROP FEED BOTH SIDES OF NEEDLE, VIBRATING PRESSER, BOBBIN NO. 5810. BALANCE WHEEL (TWO SPEED) NO. 3011. DIAMETER OF BELT GROOVES 3 AND 5 INCHES.

NO.	PLATE	NAME
*5819	—	Arm with 448 and 449.
2002	686	Dowel Pin.
4448	695	Oil Tube for intermediate bearing.
123E	691	Screw.
6109	696	Shaft for 3011.
6107	696	5977.
3005	678	Bushing (back).
448c	691	Set Screw.
*4449	—	(front).
144b	691	Screw.
4288	678	Side Cover.
286b	692	Thumb Screw.
5811	695	Spool Pin and Thread Eyelet.
8879	7801	Washer (cloth).
3011	696	Balance Wheel (two speed) 3 in. and 5 in. pulleys, with two 448c, for 6109.
5977	696	Balance Wheel (two speed) for 5981.
448c	691	Set Screw.
*5900	—	Bed with two 3016 and six 3021.
3016	679	Bed Hinge complete, Nos. 3017, 3018 and 3020.
3017	—	Bed Hinge (half butt) for 5900.
3018	—	wood table.
3020	683	Pin.
3021	686	Rivet.
5969	3642	Crank Connecting Rod with 4349 and two 158E.
*4349	—	Crank Connecting Rod Cap.
158E	691	Screw.
566c	692	Hinge Screw.
1513J	693	Nut.

From the library of: Diamond Needle Corp

NO.	PLATE	NAME
5978	696	Driving Flange with two 435c
5979	683	" " Latch
136F	691	" " Hinge Screw
435c	691	" " Set Screw
5980	683	" " Spring
330b	692	" " " Screw
5993	—	Driving Flange complete, Nos. 136F, 330b, and 5978 to 5980
5820	675	Face Plate
8181	—	" " 5820 with 2105
8182	—	Face Plate complete, Nos. 233b, 448c, 2127, 5797, 5989, 5991 and 8181
161b	691	Face Plate Screw
5902	677	Feed Bar
313c	692	" " Screw Centre
1519J	693	" " " " Nut
3032	678	" Cam with 416c
446c	691	" " Set Screw
3033	681	" Connecting Link
375c	692	" " " Hinge Screw
1518E	693	" " " " " Nut ..
5774	689	Feed Dog, 12 teeth
NOTE: No. 5774 is sent with this machine unless another Feed Dog is specified on order.		
5893	7806	Feed Dog, 21 teeth
191c	691	" " Screw
5907	3642	" Forked Connection
375c	692	" " " Hinge Screw
1518E	693	" " " " " Nut ..
5908	3642	" Lifting Rock Shaft
5909	—	Feed Lifting Rock Shaft complete, Nos. 3166 and 5908
3166	682	Feed Lifting Rock Shaft Crank with 157J and 1813
157J	691	Feed Lifting Rock Shaft Crank Clamping Screw
1813	693	Feed Lifting Rock Shaft Crank Roller and Stud
304c	692	Feed Lifting Rock Shaft Screw Centre ..
1513J	693	" " " " " Nut ..
3039	681	" Regulator
1128E	3643	" " Hinge Screw
818b	692	" " Thumb Screw
5910	3642	" Rock Shaft
5911	—	Feed Rock Shaft complete, Nos. 5910 and 5913

NO.	PLATE	NAME
5913	682	Feed Rock Shaft Crank with 453c
2049	686	" " " " Pin
453c	692	" " " " Set Screw
304c	692	" " " " Screw Centre
1513J	693	" " " " " Nut
25868	3637	Guide
747D	3641	" Thumb Screw
5826	676	Lifting Cam
902E	3646	" " Screw
5821	675	" Lever
5878	3646	" " Adjusting Screw Head
2653	3646	" " " " " Rivet
1068b	3646	" " " " " Screw
5879	3646	" " " " " Slide
5823	676	" " " " " Roller
5824	676	" " " " " " Pin ..
5835	676	" " " " " Hinge Bracket
5836	—	" " " " " 5835 with 4810
180b	691	Lifting Lever Hinge Bracket Screw
4810	683	" " " " Stud
207D	691	" " " " " Screw
3146	686	" " " " " Washer ..
5825	—	Lifting Lever complete, Nos. 1068b, 2653, 5821, 5823, 5824, 5878 and 5879
2058	680	Lifting Presser Bar
5990	681	" " " " Lifter
689c	691	" " " " " Screw
1520E	693	" " " " " " Nut
5827	675	" " " " " Lifting Bracket with two 453c
453c	692	Lifting Presser Bar Lifting Bracket Set Screw
290E	692	Lifting Presser Bar Screw Bushing
3056	678	" " " " Spring
2070	686	" " " " " Washer
5981	—	Loose Wheel Attachment complete, Nos. 5977 and 5993
5465	678	Needle Bar
*3045	681	" " Connecting Link
56815	—	" " " " " 3045 with 3147
377c	692	Needle Bar Connecting Link Hinge Screw ..
1518E	693	" " " " " " " "
		Nut
3147	3646	Needle Bar Connecting Stud with 155c ..
155c	691	" " " " " Set Screw ..

NO.	PLATE	NAME
290E	692	Needle Bar Screw Bushing.....
4803	686	Needle Clamp complete, Nos. 651D, 808F and 4802.....
808F	691	Needle Clamp Screw.....
4802	686	" " Thread Guide.....
651D	692	" " " " Screw.....
5778	696	Oil Cup.....
5779	695	" " Pad (felt).....
211D	692	" " " " Screw.....
7071	695	" " " " Washer.....
135D	691	" " Screw.....
5780	695	" " Thread Eyelet.....
5781	—	Oil Cup complete, Nos. 211D, 5778 to 5780 and 7071.....
*5970	679	Oscillating Rock Shaft with 11165.....
8163	—	" " " " 5970 with 635c, 1513J and 56812.....
3052	678	Oscillating Rock Shaft Hinge Pin.....
56812	—	" " " " " " 3052 with 1513J.....
1513J	693	Oscillating Rock Shaft Hinge Pin Nut...
635c	692	" " " " " " Screw Bearing.....
1513J	693	Oscillating Rock Shaft Hinge Pin Screw Bearing Nut.....
11165	695	Oscillating Rock Shaft Oil Pad.....
5834	3642	" " Shaft.....
5917	682	" " Collar with 453c.....
453c	692	" " " " Set Screw.....
5966	—	" " Crank.....
5967	681	Oscillating Shaft Crank complete, Nos. 453c, 1513J, 1885 and 5966.....
2049	686	Oscillating Shaft Crank Pin.....
1885	693	" " " " Roller with 190D, 1054c and 5968.....
190D	691	Oscillating Shaft Crank Roller Cap Screw
5968	686	" " " " " " " " Washer.....
1054c	3643	Oscillating Shaft Crank Roller Screw Stud
1513J	693	" " " " " " " " Nut.....
453c	692	Oscillating Shaft Crank Set Screw.....
262J	692	Pressure Regulating Thumb Screw.....
5810	684	Shuttle Bobbin (solid).....
5786	684	" " Case Latch.....
5787	684	" " " " Lever.....

NO.	PLATE	NAME
5788	684	Shuttle Bobbin Case Latch Lever Fulcrum Pin.....
5838	684	Shuttle Bobbin Case Latch Spring.....
592E	692	" " " " Stop Screw.....
5785	—	" " " " Hinge, Nos. 5786 to 5788.....
5789	684	Shuttle Bobbin Case Position Finger.....
5933	684	" " " " " " Rivet
5784	684	Shuttle Bobbin Case complete, Nos. 591E, 592E, 5785, 5789, 5838, 5933 and 5935
5934	684	Shuttle Body.....
591E	692	" Tension Regulating Screw.....
5935	684	" " Spring.....
5783	—	Shuttle, 2½ in. diam., Nos. 5784, 5810 and 5934.....
5832	677	Shuttle Driver.....
2019	686	" " Pin.....
5938	677	" Race Back.....
5939	677	" " " Spring.....
741D	691	" " " " Screw.....
5965	686	" " " Steady Pin.....
5973	—	" " Body.....
5942	677	" " Cap.....
219D	691	" " " Screw.....
5943	677	" " Frame with 5944.....
575E	3636	" " " Clamping Screw.....
5944	686	" " " Steady Pin.....
5972	677	Shuttle Race complete, Nos. 741D, 5938, 5939, 5942, 5973 and two each 219D and 5965.....
141D	3636	Shuttle Race Screw.....
5945	—	" " Slide.....
5946	677	Shuttle Race Slide complete, Nos. 5945, 5947 and two 725E.....
5947	682	Shuttle Race Slide Spring.....
725E	3636	" " " " Screw.....
1560c	693	Tension Regulating Thumb Nut.....
817c	693	" Screw Stud.....
8183	—	" " " 817c with 1560c.....
448c	691	" " " Set Screw.....
2103	685	" Spring.....
2105	686	" Thread Guard.....
5983	686	" Washer (felt).....
5984	686	" " (steel).....
5795	686	" Wheel with 5796.....
*5796	—	" " Flange.....

NO.	PLATE	NAME
5797	—	Tension complete (wheel) Nos. 2103, 5795, 8183 and two each 5983 and 5984.....
12296	686	Thread Eyelet (side of arm).....
2455	685	" Retainer Disc.....
1562J	693	" " Regulating Thumb Nut.....
418E	693	" " Screw Stud.....
10141	685	" " Spring.....
5989	—	Thread Retainer complete, Nos. 418E, 1562J, 10141 and two 2455.....
5764	680	Thread Take-up Cam with 446c, 902E and 5826.....
3012	683	Thread Take-up Cam Pin.....
446c	691	" " " Set Screw.....
*5828	675	" " Lever with 1819.....
8160	—	" " " 5828 with 1088c..
1088c	3636	" " " Hinge Screw.....
1819	693	" " " Roller and Stud..
5991	686	" " Spring.....
2127	686	" " Regulator Plate.....
233D	691	" " " " " " Screw.....
5849	—	Throat Plate Body for 5851.....
5852	—	" " " " 5854.....
5850	3645	" " Needle Hole Strip for 5851..
5853	3645	" " " " " 5854..
401E	3643	" " " " " Screw... ..
5851	3645	Throat Plate complete for 5774 and 5893, Nos. 5849, 5850 and two 401E.....
5854	3645	Throat Plate complete, for carpet mitres, for 5774 and 5893, Nos. 5852, 5853 and two 401E.....
NOTE: No. 5854 is sent with this machine unless another Throat Plate is specified on order.		
742F	692	Throat Plate Screw.....
5885	3646	Vibrating Presser Bar.....
5886	—	Vibrating Presser Bar complete, Nos. 191F, 5885 and 5887.....
5887	3646	Vibrating Presser Foot.....
191F	691	" " " Screw.....
5837	676	" " Guide Bracket.....
190D	691	" " " " Screw... ..
5830	676	" " Hinge Bracket with 453c.....
212D	691	Vibrating Presser Hinge Bracket Cap Screw.....

NO.	PLATE	NAME
453c	692	Vibrating Presser Hinge Bracket Set Screw.....
5831	676	Vibrating Presser Spring.....
233D	691	" " " Screw.....
2269	686	" " Stop Pin.....
5975	3627	Drip Pan (stand) with four wood screws $\frac{5}{8}$ in. No. 5.....
5976	—	Drip Pan (power table) with four wood screws $\frac{5}{8}$ in. No. 5.....

SINGER Needles should be used
in SINGER Machines.
These Needles and their Containers
are marked with the
Company's Trade Mark "SIMANCO.***" 1

Needles in Containers marked
"FOR SINGER MACHINES"
are NOT **SINGER** made needles. 2

LIST OF PARTS COMPLETE

FOR

MACHINE No. 42-4

FOR LEATHER. LONG BEAK CYLINDER SHUTTLE, LINK NEEDLE BAR CONNECTION, DROP FEED AT LEFT OF NEEDLE, ROLLER PRESSER, BOBBIN NO. 14535. BALANCE WHEEL (TWO SPEED) NO. 3011. DIAMETER OF BELT GROOVES 3 AND 5 INCHES.

NO.	PLATE	NAME
*8195	—	Arm with 4448 and 4449.....
2002	686	" Dowel Pin.....
4448	695	" Oil Tube for intermediate bearing..
123E	691	" Screw.....
6109	696	" Shaft for 3011.....
6107	696	" " " 5977.....
3005	678	" " Bushing (back).....
448c	691	" " " " Set Screw.....
*4449	—	" " " (front).....
144b	691	" " Screw.....
4288	678	" Side Cover.....
286b	692	" " " Thumb Screw.....
5811	695	" Spool Pin and Thread Eyelet.....
8879	7801	" " " Washer (cloth).....
3011	696	Balance Wheel (two speed) 3 in. and 5 in. pulleys, with two 448c, for 6109.....
5977	696	Balance Wheel (two speed) for 5981.....
448c	691	" " Set Screw.....
*5992	—	Bed with two 3016 and six 3021.....
3016	679	Bed Hinge complete, Nos. 3017, 3018 and 3020.....
3017	—	Bed Hinge (half butt) for 5992.....
3018	—	" " " " wood table....
3020	683	" " Pin.....
3021	686	" " Rivet.....
5969	3642	Crank Connecting Rod with 4349 and two 158E.....
*4349	—	Crank Connecting Rod Cap.....
158E	691	" " " " Screw.....
566c	692	" " " Hinge Screw.....
1513J	693	" " " " " Nut.

NO.	PLATE	NAME
5978	696	Driving Flange with two 435c.....
5979	683	" " Latch.....
136F	691	" " Hinge Screw.....
435c	691	" " Set Screw.....
5980	683	" " Spring.....
330b	692	" " " Screw.....
5993	—	Driving Flange complete, Nos. 136F, 330b and 5978 to 5980.....
5982	696	Face Plate.....
8173	—	" " 5982 with 2105.....
8179	—	Face Plate complete, Nos. 448c, 2107, 2127, 5797, 5989, 5991, 8173 and two 233b.....
164b	691	Face Plate Screw.....
2107	686	" " Thread Guard.....
233b	691	" " " " Screw.....
5839	—	Feed Bar.....
313c	692	" " Screw Centre.....
1519J	693	" " " " Nut.....
3032	678	" Cam with 446c.....
446c	691	" " Set Screw.....
3033	681	" Connecting Link.....
375c	692	" " " Hinge Screw.....
1518E	693	" " " " " Nut.
5840	3647	" Dog, 12 teeth, for canvas work.....
5855	688	" " 8 teeth (10 teeth to the inch) for leather.....
NOTE: No. 5855 is sent with this machine unless another Feed Dog is specified on order.		
5894	7806	Feed Dog, 22 teeth.....
13252	3647	" " 14 teeth (18 teeth to the inch) for leather.....
8196	3647	Feed Dog.....
5856	694	" " for cloth.....
191c	691	" " Screw.....
3037	3642	" Forked Connection.....
375c	692	" " " Hinge Screw....
1518E	693	" " " " " Nut
5996	3642	" Lifting Rock Shaft.....
8154	—	" " " " Crank with 1813 and two 1186E.....
1186E	3636	Feed Lifting Rock Shaft Crank Clamping Screw.....
5997	679	Feed Lifting Rock Shaft Crank Fork with 157J.....

NO.	PLATE	NAME
157J	691	Feed Lifting Rock Shaft Crank Fork Clamping Screw.....
1813	693	Feed Lifting Rock Shaft Crank Roller and Stud.....
3039	681	Feed Regulator.....
1128E	3643	" " Hinge Screw.....
818D	692	" " Thumb Screw.....
3042	3628	" Rock Shaft.....
3041	—	Feed Rock Shaft complete, Nos. 3042 and 3043.....
3043	682	Feed Rock Shaft Crank with 462c.....
2049	686	" " " " Pin.....
462c	3643	" " " " Set Screw.....
304c	692	" " " " Screw Centre.....
1513J	693	" " " " " Nut.....
25868	3637	Guide, for carpet mitres.....
747D	3641	" Thumb Screw.....
5981	—	Loose Wheel Attachment complete, Nos. 5977 and 5993.....
5465	678	Needle Bar.....
*3045	681	" " Connecting Link.....
56773	—	" " " " 3045 with 2052.....
377c	692	Needle Bar Connecting Link Hinge Screw.....
1518E	693	" " " " " " " Nut.....
2052	683	Needle Bar Connecting Stud with 155c.....
155c	691	" " " " " Set Screw.....
290E	692	" " " " " Screw Bushing.....
4803	686	Needle Clamp complete, Nos. 651D, 808F and 4802.....
808F	691	Needle Clamp Screw.....
4802	686	" " Thread Guide.....
651D	692	" " " " " Screw.....
5778	696	Oil Cup.....
5779	695	" " Pad (felt).....
211D	692	" " " " " Screw.....
7071	695	" " " " " Washer.....
135D	691	" " " " " Screw.....
5780	695	" " Thread Eyelet.....
5781	—	Oil Cup complete, Nos. 211D, 5778 to 5780 and 7071.....
*5970	679	Oscillating Rock Shaft with 11165.....
8163	—	" " " " 5970 with 635c, 1513J and 56812.....
3052	678	Oscillating Rock Shaft Hinge Pin.....

NO.	PLATE	NAME
56812	—	Oscillating Rock Shaft Hinge Pin 3052 with 1513J.....
1513J	693	Oscillating Rock Shaft Hinge Pin Nut.....
635c	692	" " " " " " Screw Bearing.....
1513J	693	Oscillating Rock Shaft Hinge Pin Screw Bearing Nut.....
11165	695	Oscillating Rock Shaft Oil Pad.....
8166	680	" Shaft.....
5917	682	" " Collar with 453c.....
453c	692	" " " " " Set Screw.....
5999	—	" " Crank.....
6000	3643	Oscillating Shaft Crank complete, Nos. 453c, 1513J, 1885 and 5999.....
2049	686	Oscillating Shaft Crank Pin.....
1885	693	" " " " " Roller with 190D, 1054c and 5968.....
190D	691	Oscillating Shaft Crank Roller Cap Screw.....
5968	686	" " " " " " " Washer.....
1054c	3643	Oscillating Shaft Crank Roller Screw Stud.....
1513J	693	" " " " " " " Nut.....
453c	692	Oscillating Shaft Crank Set Screw.....
3054	678	Presser Bar.....
5990	681	" " " " " Lifter.....
689c	691	" " " " " " " Screw.....
1520E	693	" " " " " " " Nut.....
5608	679	" " " " " " " Lifting Bracket with 453c.....
453c	692	" " " " " " " Set Screw.....
290E	692	" " " " " " " Screw Bushing.....
3056	678	" " " " " " " Spring.....
2070	686	" " " " " " " Washer.....
5971	687	" " " " " " " Foot (long shank).....
8151	7806	" " " " " " " for 5856.....
190D	691	" " " " " " " Screw.....
262J	692	Pressure Regulating Thumb Screw.....
1875	—	Roller with 634D and 1528J.....
8152	—	" Arm.....
440F	691	" " " " " " " Adjusting Screw.....
1547J	693	" " " " " " " " " Nut.....
2206	—	" " " " " " " Bracket.....
316F	692	" " " " " " " " " Screw Centre.....
1547J	693	" " " " " " " " " Nut.....
2205	695	" " " " " " " " " Lock Spring.....
176D	691	" " " " " " " " " Screw.....
1549J	693	" " " " " " " " " Nut.....

NO.	PLATE	NAME
634D	692	Roller Screw.....
1528J	693	" " Nut.....
5964	687	Roller Presser, 1½ in. roller, complete, Nos. 176b, 440F, 1549J, 1875, 2205, 2206, 8152, two 316F and three 1547J.....
190D	691	Roller Presser Serew.....
14535	685	Shuttle Bobbin.....
8187	3634	" Cylinder.....
8194	—	" " 8187 with 773F and 8188.....
12000	685	" " Hinge Pin.....
12001	685	" " Latch.....
12002	685	" " Pin.....
11854	3634	" " " Spring.....
590D	692	" " " " Screw.....
5752	685	" Frame.....
8162	—	" " 5752 with 590b, 11854, 12001 and 12002.....
773F	692	Shuttle Tension Regulating Serew.....
8188	3634	" " Spring.....
8189	3634	Shuttle (cylinder) 2½ in. diam., complete, Nos. 8162, 8194, 12000 and 14535.....
5833	679	Shuttle Driver.....
2022	3634	" " Pin.....
5848	3635	" Race Back.....
5939	677	" " " Spring.....
5842	3634	" " " " Rest Pin.....
933D	3634	" " " " Screw.....
5965	686	" " " Steady Pin.....
5843	3635	" " " Body.....
*8193	—	" " " 5843 with 5842, 5844, 5845 and two each 219D, 934J and 5965.....
5844	3636	Shuttle Race Cap (left).....
5845	3636	" " " (right).....
219D	691	" " " Screw (large).....
934J	3636	" " " " (small).....
5841	—	Shuttle Race complete, Nos. 933D, 5848, 5939 and 8193.....
5943	677	Shuttle Race Frame with 5944.....
575E	3636	" " " Clamping Serew.....
5944	686	" " " Steady Pin.....
141D	3636	" " " Screw.....
5945	—	" " " Slide.....
5946	677	Shuttle Race Slide complete, Nos. 5945, 5947 and two 725E.....
5947	682	Shuttle Race Slide Spring.....
725E	3636	" " " " Screw.....
1560C	693	Tension Regulating Thumb Nut.....

NO.	PLATE	NAME
817C	693	Tension Serew Stud.....
8183	—	" " " 817C with 1560C.....
448C	691	" " " Set Serew.....
2103	685	" Spring.....
2105	686	" Thread Guard.....
5983	686	" Washer (felt).....
5984	686	" " (steel).....
5795	686	" Wheel with 5796.....
*5796	—	" " Flange.....
5797	—	Tension complete (wheel) Nos. 2103, 5795, 8183 and two each 5983 and 5984.....
12296	686	Thread Eyelet (side of arm).....
2455	685	" Retainer Disc.....
1562J	693	" " Regulating Thumb Nut.....
418E	693	" " Serew Stud.....
10141	685	" " Spring.....
5989	—	Thread Retainer complete, Nos. 418E, 1562J, 10141 and two 2455.....
*8185	—	Thread Take-up Cam.....
5757	678	" " " 8185 with 446C.....
3012	683	" " " Pin.....
446C	691	" " " Set Serew.....
*5758	678	" " " Lever with 1819.....
8159	—	" " " 5758 with 1088C.....
1088C	3636	" " " Hinge Serew.....
1819	693	" " " Roller and Stud.....
5991	686	" " " Spring.....
2127	686	" " " Regulator Plate.....
233D	691	" " " " ".....
5759	688	Serew.....
		Throat Plate for 5855 and 13252.....
		NOTE: No. 5759 is sent with this machine unless another Throat Plate is specified on order.
5804	694	Throat Plate for 5856.....
5880	—	" " " Body for 5881.....
8197	—	" " " " 8199.....
5853	3645	" " " Needle Hole Strip for 5881..
8198	3647	" " " " " 8199..
401E	3643	" " " " " Serew....
5881	3647	Throat Plate complete for 5840 and 5894, Nos. 5853, 5880 and two 401E.....
8199	3647	Throat Plate complete for 8196, Nos. 8197, 8198 and two 401E.....
742F	692	Throat Plate Serew.....
5975	3627	Drip Pan (stand) with four wood serews 5/8 in. No. 5.....
5976	—	Drip Pan (power table) with four wood serews 5/8 in. No. 5.....

LIST OF PARTS COMPLETE

FOR

MACHINE No. 42-8

FOR AWNINGS, SAILS, TARPAULINS, TRUNK COVERS, ETC.
CENTRAL BOBBIN, DROP FEED, ALTERNATING PRESSERS,
BOBBIN NO. 5810. BALANCE WHEEL (TWO SPEED)
NO. 3011. DIAMETER OF BELT GROOVES 3 AND 5
INCHES.

NO.	PLATE	NAME
*5801	—	Arm with 4418 and 4449.....
2002	686	" Dowel Pin.....
4448	695	" Oil Tube for intermediate bearing..
123E	691	" Screw.....
6178	3628	" Shaft for 3011.....
6179	3628	" " " 5977.....
3005	678	" " Bushing (back).....
448c	691	" " " " Set Screw.....
*4449	—	" " " (front).....
144D	691	" " Screw.....
4288	678	" Side Cover.....
286D	692	" " " Thumb Screw.....
5811	695	" Spool Pin and Thread Eyelet.....
8879	7801	" " " Washer (cloth).....
3011	696	Balance Wheel (two speed) 3 in. and 5 in. pulleys, with two 448c, for 6178.....
5977	696	Balance Wheel (two speed) for 5981.....
448c	691	" " " Set Screw.....
*5992	—	Bed with two 3016 and six 3021.....
3016	679	Bed Hinge complete, Nos. 3017, 3018 and 3020.....
3017	—	Bed Hinge (half butt) for 5992.....
3018	—	" " " " " wood table.....
3020	683	" " Pin.....
3021	686	" " Rivet.....
5969	3642	Crank Connecting Rod with 4349 and two 158E.....
*4349	—	Crank Connecting Rod Cap.....
158E	691	" " " " Screw.....
566c	692	" " " Hinge Screw.....
1513J	693	" " " " " Nut

NO.	PLATE	NAME
5978	696	Driving Flange with two 435c.....
5979	683	" " Latch.....
136F	691	" " " Hinge Screw.....
435c	691	" " Set Screw.....
5980	683	" " Spring.....
330D	692	" " " Screw.....
5993	—	Driving Flange complete, Nos. 136F, 330D and 5978 to 5980.....
5791	696	Face Plate.....
8174	—	" " 5791 with 2105.....
8178	—	Face Plate complete, Nos. 233D, 448c, 2108, 2127, 5797, 5989, 5991 and 8174
175D	691	Face Plate Screw.....
2108	686	" " Thread Guard.....
5902	677	Feed Bar.....
313c	692	" " Screw Centre.....
1519J	693	" " " " Nut.....
3032	678	" Cam with 446c.....
446c	691	" " Set Screw.....
3033	681	" Connecting Link.....
375c	692	" " " Hinge Screw.....
1518E	693	" " " " " Nut.....
5812	694	" Dog.....

NOTE: No. 5812 is sent with this machine unless
another Feed Dog is specified on order.

8157	3648	Feed Dog, 19 teeth (18 teeth to the inch)
5888	3648	" " 11 teeth (10 teeth to the inch)
191c	691	" " Screw.....
3037	3642	" Forked Connection.....
375c	692	" " " Hinge Screw.....
1518E	693	" " " " " Nut
5815	3642	" Lifting Rock Shaft.....
3166	682	" " " Crank with 157J and 1813.....
157J	691	Feed Lifting Rock Shaft Crank Clamping Screw.....
5997	679	Feed Lifting Rock Shaft Crank Fork with 157J.....
157J	691	Feed Lifting Rock Shaft Crank Fork Clamping Screw.....
1813	693	Feed Lifting Rock Shaft Crank Roller and Stud.....
3039	681	Feed Regulator.....
1128E	3643	" " Hinge Screw.....
818D	692	" " Thumb Screw.....
3042	3628	" Rock Shaft.....

NO.	PLATE	NAME
3041	—	Feed Rock Shaft complete, Nos. 3042 and 3043.....
3043	682	Feed Rock Shaft Crank with 462c.....
2049	686	" " " " Pin.....
462c	3643	" " " " Set Screw.....
304c	692	" " " " Screw Centre.....
1513J	693	" " " " " Nut.....
25868	3637	Guide, for carpet mitres.....
3126	680	" " Bar.....
56752	—	" " " 3126 with 2361 and two 2362
56844	—	" " " 56752 with 337D and 3137.....
4730	—	Guide Bar complete, Nos. 810b, 810e, 3134, 4723, 4897, 56844 and three 404b
4854	3633	Guide Bar Driving Crank with 1862 and 3131.....
1862	3633	Guide Bar Driving Crank Roller.....
3131	3633	" " " " " Cap.....
3094	686	" " " " " Wedge.....
690E	691	" " " " " Adjusting Screw.....
4723	683	Guide Bar Lifting Bracket.....
404D	692	" " " " " Screw.....
747D	3641	" " Thumb Screw.....
2058	680	Lifting Presser Bar.....
3133	680	" " " Bracket with 641E and 1823.....
641E	691	Lifting Presser Bar Bracket Clamping Screw.....
1823	693	Lifting Presser Bar Bracket Roller and Stud.....
4855	3641	Lifting Presser Bar Lifter.....
598c	691	" " " " " Screw.....
4725	695	" " " " Lifting Bracket.....
4726	695	" " " " " Guide Pin.....
3100	679	Lifting Presser Bar Spring.....
2070	686	" " " " " Washer.....
5816	694	" " " Foot.....
193D	691	" " " " " Screw.....
5981	—	Loose Wheel Attachment complete, Nos. 5977 and 5993.....
4264	680	Needle Bar.....
*4898	3633	" " " Connecting Link with 390c.....
56764	—	" " " " " 4898 with 15472.....
390c	692	Needle Bar Connecting Link Adjusting Screw.....

NO.	PLATE	NAME
15472	3633	Needle Bar Connecting Stud with 155c.....
155c	691	" " " " " Set Screw.....
4265	686	" " Clamp with 196F.....
4865	3643	Needle Clamp complete, Nos. 651D, 4265 and 4266.....
4266	686	Needle Clamp Thread Guide.....
651D	692	" " " " " Screw.....
196F	676	" " " " " Screw.....
5778	696	Oil Cup.....
5779	695	" " " Pad (felt).....
211D	692	" " " " " Screw.....
7071	695	" " " " " Washer.....
135D	691	" " " " " Screw.....
5780	695	" " " Thread Eyelet.....
5781	—	Oil Cup complete, Nos. 211D, 5778 to 5780 and 7071.....
*5970	679	Oscillating Rock Shaft with 11165.....
8163	—	" " " " " 5970 with 635c, 1513J and 56812.....
3052	678	Oscillating Rock Shaft Hinge Pin.....
56812	—	" " " " " " 3052 with 1513J.....
1513J	693	Oscillating Rock Shaft Hinge Pin Nut.....
635c	692	" " " " " " " Screw Bearing.....
1513J	693	Oscillating Rock Shaft Hinge Pin Screw Bearing Nut.....
11165	695	Oscillating Rock Shaft Oil Pad.....
5834	3642	" " Shaft.....
5917	682	" " " Collar with 453c.....
453c	692	" " " " " Set Screw.....
5966	—	" " " " " Crank.....
5967	681	Oscillating Shaft Crank complete, Nos. 453c, 1513J, 1885 and 5966.....
2049	686	Oscillating Shaft Crank Pin.....
1885	693	" " " " " Roller with 190D, 1054c and 5968.....
190D	691	Oscillating Shaft Crank Roller Cap Screw.....
5968	686	" " " " " " " " " Washer.....
1054c	3643	Oscillating Shaft Crank Roller Screw Stud.....
1513J	693	" " " " " " " " " Nut.....
453c	692	Oscillating Shaft Crank Set Screw.....
262J	692	Pressure Regulating Thumb Screw.....
5810	684	Shuttle Bobbin (solid).....
5786	684	" " " Case Latch.....

NO.	PLATE	NAME
5787	684	Shuttle Bobbin Case Latch Lever
5788	684	" " " " " Fulerum Pin
5838	684	Shuttle Bobbin Case Latch Spring
592E	692	" " " " Stop Screw
5785	—	" " " Hinge, Nos. 5786 to 5788
5789	681	Shuttle Bobbin Case Position Finger
5933	684	" " " " Rivet
5784	684	Shuttle Bobbin Case complete, Nos. 591F, 592E, 5785, 5789, 5838, 5933 and 5935
5934	684	Shuttle Body
591F	692	" Tension Regulating Screw
5935	684	" " Spring
5783	—	Shuttle, 2½ in. diam., Nos. 5784, 5810 and 5934
5832	677	Shuttle Driver
2049	686	" " Pin
5938	677	" Race Back
5939	677	" " Spring
741D	691	" " " Screw
5965	686	" " " Steady Pin
5973	—	" " Body
5942	677	" " Cap
219D	691	" " Screw
5943	677	" " Frame with 5944
575E	3636	" " " Clamping Screw
5944	686	" " " Steady Pin
5972	677	Shuttle Race complete, Nos. 741D, 5938, 5939, 5942, 5973 and two each 219D and 5965
141D	3636	Shuttle Race Screw
5945	—	" " Slide
5946	677	Shuttle Race Slide complete, Nos. 5945, 5947 and two 725E
5947	682	Shuttle Race Slide Spring
725E	3636	" " " Screw
1560C	693	Tension Regulating Thumb Nut
817C	693	" Screw Stud
8183	—	" " " 817C with 1560C
448C	691	" " " Set Screw
2103	685	" Spring
2105	686	" Thread Guard
5983	686	" Washer (felt)
5984	686	" " (steel)
5795	686	" Wheel with 5796
*5796	—	" " Flange

NO.	PLATE	NAME
5797	—	Tension complete (wheel) Nos. 2103, 5795, 8183 and two each 5983 and 5984
12296	686	Thread Eyelet (side of arm)
2455	685	" Retainer Disc
1562L	693	" " Regulating Thumb Nut
418E	693	" " Screw Stud
1014L	685	" " Spring
5989	—	Thread Retainer complete, Nos. 418E, 1562L, 1014L and two 2455
5817	680	Thread Take-up Cam with 446C
3012	683	" " " Pin
446C	691	" " " Set Screw
*5954	678	" " Lever with 1819
8164	—	" " " 5954 with 1088C
1088C	3636	" " " Hinge Screw
1819	693	" " " Roller and Stud
5991	686	" " Spring
2127	686	" " " Regulator Plate
233D	691	" " " " "
5865	—	Screw
5865	—	Throat Plate Body
5866	3644	" " Needle Hole Strip
401E	3643	" " " " " Screw
5867	3644	Throat Plate complete for 5812, Nos. 5865, 5866 and two 401E
NOTE: No. 5867 is sent with this machine unless another Throat Plate is specified on order.		
5889	3648	Throat Plate for 5888 and 8157
742D	692	" " Screw
3134	3633	Vibrating Presser Bar
2361	3633	" " " Hinge Bracket
2362	3633	" " " " " Rivet
810D	3633	Vibrating Presser Bar Hinge Cap Screw
4897	3633	" " " Lifting Bell Crank
810E	3633	" " " " " "
		Hinge Cap Screw
3137	3633	Vibrating Presser Bar Spring
337D	692	" " " " Screw
5814	694	" " Foot
217F	691	" " " Screw
5975	3627	Drip Pan (stand) with four wood screws 5/8 in. No. 5
5976	—	Drip Pan (power table) with four wood screws 5/8 in. No. 5

ACCESSORIES

NO.	PLATE	NAME
27056	3637	Machine Button with wood screw 1 3/4 in. No. 14 R. H. B.
41400	3637	Machine Rest Pin (wood)
120312	3637	Oiler (copper plated) with 120343
120343	3637	" Spout, 3 1/2 in. long
26026	3637	Screw Driver (large)
26185	3637	" " (small)
4347	3637	Wrench for 1513 and 1518
4822	680	" " 1528, 1547 and 1519

BINDERS (Adjustable)

NO.	PLATE	NAME
36310	5807	Bed with two each 1036c and 1266c
36341	5807	Edge Guide
671D	5807	" " Thumb Screw
36342	5807	Guide (lower)
36343	5807	" (upper)
286D	5807	" Thumb Screw
1036c	7790	Leveling Screw (back)
1266c	3643	" " (front)
36344	5807	Binder (adjustable) complete, for leather binding, for canvas bags, leggings, etc., for 42-8 Machine, Nos. 286D, 671D and 36340 to 36343
36345	7793	Lifting Presser Foot for 36344
36346	7793	Vibrating Presser Foot for 36344
120242	7790	Bed with 1036c
120243	7791	Folder (lower) for 120248
120244	7790	" (upper) for 120247 and 120248
120245	7790	Guide (centre) for 120247 and 120248
120246	7790	" (lower) for 120247
286D	692	" Thumb Screw
1036c	7790	Leveling Screw
120247	7790	Binder (adjustable) complete, to turn in upper edge only, for light or medium weight material, Nos. 286D, 120242 and 120244 to 120246
120248	7791	Binder (adjustable) complete, to turn in both edges, for light or medium weight material, Nos. 286D and 120242 to 120245

BINDERS (ADJUSTABLE)

NO.	PLATE	NAME
5776	688	Feed Dog for 120247 and 120248, for 42-8 Machine
28335	3610	Lifting Presser Foot for 120247 and 120248, for 42-8 Machine
5777	688	Throat Plate for 5776
5890	7793	Vibrating Presser Foot for 120247 and 120248, for 42-8 Machine

BINDER (English)

FOR MATTRESSES FOR 42-8 MACHINE

NO.	PLATE	NAME
5888	3610	Feed Dog, 11 teeth (10 teeth to the inch)
28334	1380	Folder
193F	691	" Screw
7071	695	" " Washer
28335	3610	Lifting Presser Foot
26617	3643	Ribbon Tension Pin (bent)
26486	3643	" " " (straight)
28336	—	" " Plate
28337	1380	Ribbon Tension complete, Nos. 26617, 28336 and eight 26486
233D	1380	Ribbon Tension Screw
28338	3610	Throat Plate for 5888
28339	3610	Vibrating Presser Foot
28340	—	Binder (English) complete, Nos. 193F, 5888, 7071, 28334, 28335, 28337 to 28339 and two 233D

BINDERS ON SHANK

NO.	PLATE	NAME
26998	3625	Binder on Shank, for binding canvas with leather, for 42-1 and 42-3 Machines
26997	3625	Presser Foot for 26998, for 42-1 Machine
26999	3625	Binder on Shank, for horse carpet aprons, for 42-2 Machine
28301	7795	Binder on Shank, for carpet matting, for 42-8 Machine
28305	3600	Binder on Shank, for circular binding, for 42-1 Machine
28302	3600	Feed Dog for 28305

NO.	PLATE	NAME
28303	3600	Presser Foot for 28305
28304	3600	Throat Plate for 28302
28311	3602	Binder (horn) on Shank for 42-1 Machine
28310	3602	Presser Foot for 28311
28319	3605	Binder on Shank, for binding leather with turned edge binding of leather, for 42-8 Machine
28321	3604	Binder on Shank, for saddle housing, for 42-3 Machine
5776	3605	Feed Dog for 28321
28320	3605	Throat Plate for 5776
28322	3606	Binder on Shank, for binding carpets, for 42-3 Machine
35090	7795	Binder on Shank, for leather, for 42-1 Machine
35086	3621	Feed Dog for 35090
35088	3621	Throat Plate for 35086

CORDERS

When ordering Corders, or parts thereof, state size or number of cords to the inch.

NO.	PLATE	NAME
26795	7792	Cord Guide
26796	7792	" " Arm
1044d	7792	" " Hinge Screw
28328	7792	" " Bed
26798	7792	" " Bracket
6037	7792	" " Rivet
190d	691	" " Screw
28329	7792	Corder (adjustable) complete, for buggy cushions, Nos. 190d, 1044d, 26795, 26796, 26798, 28328 and three 6037
36519	7792	Presser Foot (grooved) for 28329 for 42-4 Machine

FOR COVERING CORD WITH THIN LEATHER

FOR 42-8 MACHINE

NO.	PLATE	NAME
28316	7793	Feed Dog (grooved)
28314	7793	Lifting Presser Foot
28317	7793	Throat Plate (grooved) for 28316
28315	7793	Vibrating Presser Foot

EDGE FOLDER

FOR 42-8 MACHINE

NO.	PLATE	NAME
36999	7795	Edge Folder on Shank, for leather work, to turn the edge down

HEMMERS ON SHANK

NO.	PLATE	NAME
27000	3626	Hemmer on Shank, for canvas, for 42-8 Machine
28318	3604	Hemmer and Corder on Shank for 42-2 Machine

PIPING ATTACHMENTS

NO.	PLATE	NAME
28313	3602	Piping Attachment, for car cushions, for 42-2 Machine
28312	3602	Presser Foot (grooved) for 28313
35923	7794	Piping Attachment for 42-3 Machine
35924	7794	Presser Foot for 35923
26800	7794	Piping Attachment on Shank for 42-8 Machine
120099	7794	Lifting Presser Foot for 26800
120100	7794	Vibrating Presser Foot for 26800

PRESSER FOOT

NO.	PLATE	NAME
26996	3622	Lifting Presser Foot with stitch set for 42-8 Machine

THROAT PLATE

NO.	PLATE	NAME
28308	7806	Feed Dog for 42-2 Machine
28309	7806	Throat Plate for 28308 for 25721

WELT GAUGE ON SHANK

NO.	PLATE	NAME
35086	3621	Feed Dog for 35089
35087	3621	Presser Foot for 35089
35088	3621	Throat Plate for 35086

NO.	PLATE	NAME
35089	3622	Welt Gauge on Shank, for inserting corded welt, for upholstering, etc., for 42-1 Machine.....
35086	3621	Feed Dog for 35094.....
35092	3623	Lifting Presser Foot for 35094.....
35088	3621	Throat Plate for 35086.....
35093	3623	Vibrating Presser Foot for 35094.....
35141	3623	Bed.....
26795	3623	Cord Guide.....
26796	3623	" " Arm.....
1044D	7792	" " " Screw.....
26798	3623	" " Bracket.....
6037	7792	" " " Rivet.....
190D	691	" " " Screw.....
35094	3623	Welt Gauge (adjustable, hinged) for making or inserting corded welt, for 42-8 Machine, Nos. 190D, 1044D, 26795, 26796, 26798, 35141 and three 6037....

BOBBIN WINDERS

BOBBIN WINDER

FOR 42-1 TO 42-3 AND 42-8 MACHINES

NO.	PLATE	NAME
5958	680	Bracket.....
159D	691	" " Screw.....
5959	680	Frame.....
5957	—	Frame complete, Nos. 333D and 5959 to 5963.....
46D	691	Frame Hinge Screw.....
5960	678	Friction Wheel (leather).....
5961	678	" " " Washer.....
333D	692	" " " " Screw.....
5962	678	Spindle.....
5963	678	" " Flange.....
11114	682	Spring.....
190D	691	" " " Screw.....
5974	680	Bobbin Winder complete, Nos. 46D, 190D, 5957, 5958 and 11114.....

BOBBIN WINDER

FOR 42-4 MACHINE

NO.	PLATE	NAME
5958	3638	Bracket.....
159D	691	" " " Screw.....

NO.	PLATE	NAME
5959	3638	Frame.....
5809	—	Frame complete, Nos. 333D, 5761, 5959 to 5961 and 5963.....
46D	691	Frame Hinge Screw.....
5960	3638	Friction Wheel (leather).....
5961	3638	" " " Washer.....
333D	692	" " " " Screw.....
5761	3638	Spindle.....
5963	3638	" " Flange.....
11114	3638	Spring.....
190D	691	" " " Screw.....
5762	3638	Bobbin Winder complete, Nos. 46D, 190D, 5809, 5958 and 11114.....

BOBBIN WINDER

(SWINGING AUTOMATIC, RIGHT HAND)

FOR 5810

NO.	PLATE	NAME
27540	7800	Base.....
27302	7805	Frame.....
50356D	7801	" " " Hinge Screw.....
1620J	7801	" " " " Nut.....
27303	7801	" " " Spring.....
27541	7800	Pulley.....
27333	7805	Spindle.....
27306	7800	Spool Pin.....
27307	7800	" " Stand.....
27308	7800	Spool Stand complete, Nos. 418E, 1562J, 2106, 10141, 11241, 27306, 27307 and two each 2455 and wood screws 1 in. No. 10.....
11241	7800	Spool Washer (cloth).....
27334	7805	Stop Latch.....
35D	7801	" " " Hinge Screw.....
2455	685	Tension Disc.....
1562J	693	" " " Regulating Thumb Nut.....
418E	693	" " " Screw Stud.....
10141	685	" " " Spring.....
2106	7801	" " " Thread Guide.....
27648	7805	Bobbin Winder, Nos. 35D, 1620J, 27302, 27303, 27333, 27334, 27540, 27541, 50356D and two wood screws 1 in. No. 7.....
27548	—	Bobbin Winder (swinging automatic, right hand) complete, Nos. 27308 and 27648.....

BOBBIN WINDER

(SWINGING AUTOMATIC, RIGHT HAND)

FOR 14535

NO.	PLATE	NAME
27540	7800	Base
15072	7801	Bobbin Position Pin
27527	7800	Frame
50356D	7801	" Hinge Screw
1620J	7801	" " " Nut
27303	7801	" Spring
27541	7800	Pulley
27330	7800	Spindle with 15072
27306	7800	Spool Pin
27307	7800	" Stand
27308	7800	Spool Stand complete, Nos. 418E, 1562J, 2106, 10141, 11241, 27306, 27307 and two each 2455 and wood screws 1 in. No. 10
11241	7800	Spool Washer (cloth)
27331	7800	Stop Latch
35D	7801	" " Hinge Screw
2455	685	Tension Disc
1562J	693	" Regulating Thumb Nut
418E	693	" Screw Stud
10141	685	" Spring
2106	7801	" Thread Guide
27649	7800	Bobbin Winder, Nos. 35D, 1620J, 27303, 27330, 27331, 27527, 27540, 27541, 50356D and two wood screws 1 in. No. 7
27549	—	Bobbin Winder (swinging automatic, right hand) complete, Nos. 27308 and 27649

BOBBIN WINDER

(SWINGING AUTOMATIC, RIGHT HAND)

FOR FLAT OR ROUND BELT, FOR 14535

NO.	PLATE	NAME
41439	7804	Base with 458c, 27916 and two 28084...
41398	3583	Bobbin Carrier Key
27916	3583	Brake (leather)
28084	3583	" Rivet

NO.	PLATE	NAME
41440	3581	Frame
41441	3581	" Hinge Pin
458c	3583	" " " Set Screw
4784	3583	" Oil Pad
41442	3581	" Spring
41443	3581	Pulley with 155c
155c	3583	" Set Screw
41444	7804	Spindle with 41398
41445	7804	Stop Latch
41446	7804	" " Hinge Pin
2269	3583	" " Pin
41447	3581	Tripping Arm with 176D
176D	3583	" " Clamping Screw
41448	7804	Bobbin Winder, Nos. 2269, 41439 to 41447, two 4784 and three wood screws 1 in. No. 7

THREAD UNWINDER PARTS

27555	3582	Spool Pin
41450	3582	" Rest
41451	—	" " 41450 with 138B and 27555..
138B	3583	" " Set Screw
27557	3582	" Stand with 138B
41514	3582	" Weight, 4 in. diam., with 41515...
41515	3583	" " Centre Pin
2102	3583	Tension Disc
1560c	3583	" Regulating Thumb Nut
828c	7801	" Screw Stud
2103	3583	" Spring
5769	3583	" Thread Eyelet
17547	7801	" " Guard
60608	3582	Thread Guard
27560	3582	" " Rod, 26 in. long
138B	3583	" " " Set Screw
330D	3583	" " " Set Screw
60609	—	Thread Guard complete, Nos. 330D, 828c, 1560c, 2103, 5769, 17547, 60608 and two 2102
41454	3582	Thread Unwinder complete, for one large spool, Nos. 27557, 27560, 41451, 41514, 60609 and three wood screws 1¼ in. No. 12
41449	—	Bobbin Winder (swinging automatic, right hand) complete, Nos. 41448 and 41454

KNEE LIFTER PARTS

(POWER TABLE)

FOR 42-1 TO 42-4 MACHINES

NO.	PLATE	NAME
5871	3638	Bell Crank.....
13253	—	“ “ 5871 with 5599 and 5601.....
5599	3638	“ “ Bracket.....
178E	691	“ “ “ Screw.....
5601	3641	“ “ Hinge Pin.....
5735	3641	“ “ Spring.....
5872	3638	Bell Crank complete, Nos. 5735 and 13253
5607	3642	Lifting Lever.....
5614	679	“ “ Connecting Rod.....
802D	691	“ “ Hinge Screw.....
5772	3628	Rock Shaft.....
7539	3628	“ “ Hanger with two wood screws 1 in. No. 10.....
2765	3628	Rock Shaft Knee Arm.....
2768	—	Rock Shaft Knee Arm complete, Nos. 2765 to 2767.....
2766	3628	Rock Shaft Knee Arm Hub with 356c....
356c	693	“ “ “ “ “ Set Screw....
2767	3628	“ “ “ Plate with 356c.....
356c	693	“ “ “ “ “ Set Screw.....
6337	3628	“ “ Lifting Bracket with two 356c
12243	3628	“ “ “ “ Hook.....
356c	693	“ “ “ “ “ Set Screw
356c	693	“ “ “ “ “ Set Screw....
2770	3628	“ “ Stop Dog with 356c.....
356c	693	“ “ “ “ “ Set Screw.....
5773	3628	Rock Shaft complete, Nos. 2768, 2770, 5772, 6337, 12243 and two 7539.....
5873	—	Knee Lifter complete (power table) Nos. 802D, 5607, 5614, 5773, 5872 and two 178E.....

KNEE LIFTER PARTS

(STAND)

FOR 42-1 TO 42-4 MACHINES

NO.	PLATE	NAME
5871	3638	Bell Crank.....
13253	—	“ “ 5871 with 5599 and 5601.....
5599	3638	“ “ Bracket.....

KNEE LIFTER PARTS

NO.	PLATE	NAME
178E	691	Bell Crank Bracket Screw.....
5601	3641	“ “ Hinge Pin.....
5735	3641	“ “ Spring.....
5872	3638	Bell Crank complete, Nos. 5735 and 13253
5607	3642	Lifting Lever.....
5614	679	“ “ Connecting Rod.....
802D	691	“ “ Hinge Screw.....
5772	3628	Rock Shaft.....
7539	3628	“ “ Hanger with two wood screws 1 in. No. 10.....
2765	3628	Rock Shaft Knee Arm.....
2768	—	Rock Shaft Knee Arm complete, Nos. 2765 to 2767.....
2766	3628	Rock Shaft Knee Arm Hub with 356c....
356c	693	“ “ “ “ “ Set Screw....
2767	3628	“ “ “ Plate with 356c.....
356c	693	“ “ “ “ “ Set Screw.....
6337	3628	“ “ Lifting Bracket with two 356c
2778	3628	“ “ “ “ Hook.....
356c	693	“ “ “ “ “ Set Screw.....
356c	693	“ “ “ “ “ Set Screw....
2770	3628	“ “ Stop Dog with 356c.....
356c	693	“ “ “ “ “ Set Screw.....
5875	—	Rock Shaft complete, Nos. 2768, 2770, 2778, 5772, 6337 and two 7539.....
5876	—	Knee Lifter complete (stand) Nos. 802D, 5607, 5614, 5872, 5875 and two 178E...

KNEE LIFTER PARTS

(POWER TABLE)

FOR 42-8 MACHINE

NO.	PLATE	NAME
5871	3638	Bell Crank.....
13253	—	“ “ 5871 with 5599 and 5601.....
5599	3638	“ “ Bracket.....
178E	691	“ “ “ Screw.....
5601	3641	“ “ Hinge Pin.....
5735	3641	“ “ Spring.....
5872	3638	Bell Crank complete, Nos. 5735 and 13253
4724	3638	Lifting Lever with 448c.....
4728	3638	“ “ Connecting Rod.....
12416	3641	“ “ “ “ Joint.....
76D	691	“ “ “ “ “ Hinge Screw.....

NO.	PLATE	NAME
1521E	693	Lifting Lever Connecting Rod Lock Nut.
802D	691	" " Hinge Screw.....
4727	695	" " Pin.....
448C	691	" " " Set Screw.....
5772	3628	Rock Shaft.....
7539	3628	" " Hanger with two wood screws 1 in. No. 10.....
2765	3628	Rock Shaft Knee Arm.....
2768	—	Rock Shaft Knee Arm complete, Nos. 2765 to 2767.....
2766	3628	Rock Shaft Knee Arm Hub with 356c....
356C	693	" " " " " Set Screw....
2767	3628	" " " Plate with 356c.....
356C	693	" " " " " Set Screw.....
6337	3628	" " Lifting Bracket with two 356c
12243	3628	" " " " " Hook.....
356C	693	" " " " " Set Screw
356C	693	" " " " " Set Screw....
2770	3628	" " Stop Dog with 356c.....
356C	693	" " " " " Set Screw.....
5773	3628	Rock Shaft complete, Nos. 2768, 2770, 5772, 6337, 12243 and two 7539.....
5874	—	Knee Lifter complete (power table) Nos. 76D, 802D, 1521E, 4724, 4727, 4728, 5773, 5872, 12416 and two 178E.....

KNEE LIFTER PARTS

(STAND)

FOR 42-8 MACHINE

NO.	PLATE	NAME
5871	3638	Bell Crank.....
13253	—	" " 5871 with 5599 and 5601.....
5599	3638	" " Bracket.....
178E	691	" " " Screw.....
5601	3641	" " Hinge Pin.....
5735	3641	" " Spring.....
5872	3638	Bell Crank complete, Nos. 5735 and 13253
4724	3638	Lifting Lever with 448c.....
4728	3638	" " Connecting Rod.....
12416	3641	" " " " " Joint.....
76D	691	" " " " " Hinge Screw.....
1521E	693	Lifting Lever Connecting Rod Lock Nut.
802D	691	" " Hinge Screw.....

NO.	PLATE	NAME
4727	695	Lifting Lever Pin.....
448C	691	" " " Set Screw.....
5772	3628	Rock Shaft.....
7539	3628	" " Hanger with two wood screws 1 in. No. 10.....
2765	3628	Rock Shaft Knee Arm.....
2768	—	Rock Shaft Knee Arm complete, Nos. 2765 to 2767.....
2766	3628	Rock Shaft Knee Arm Hub with 356c....
356C	693	" " " " " Set Screw....
2767	3628	" " " Plate with 356c.....
356C	693	" " " " " Set Screw.....
6337	3628	" " Lifting Bracket with two 356c
2778	3628	" " " " " Hook.....
356C	693	" " " " " Set Screw
356C	693	" " " " " Set Screw....
2770	3628	" " Stop Dog with 356c.....
356C	693	" " " " " Set Screw.....
5875	—	Rock Shaft complete, Nos. 2768, 2770, 2778, 5772, 6337 and two 7539.....
5877	—	Knee Lifter complete (stand) Nos. 76D, 802D, 1521E, 4724, 4727, 4728, 5872, 5875, 12416 and two 178E.....

STAND

ROCKING TREADLE

NO.	PLATE	NAME
25133	7802	Band Wheel (two speed) 10 in. and 12 in. diam., with 2117 and 25010.....
25010	7802	Band Wheel Crank.....
2117	695	" " " Pin.....
297C	692	" " " " " Screw Centre.....
46629	—	" " " " " 297c with 1507J.....
1507J	693	Band Wheel Crank Screw Centre Nut....
25136	—	Belt, size $\frac{3}{8}$ in., length 62 $\frac{1}{2}$ in., with 25029
25029	695	" Hook.....
46667	—	Brace.....
46533	7802	" 46667 with three 46629.....
46662	7803	Brace (sectional) complete, Nos. 46528, 46663 and three 880E.....
748E	7801	Brace Screw.....
46528	7803	" Section (left) with 46629.....
46663	7803	" " (right) with two 46629....

NO.	PLATE	NAME
880E	7801	Brace Section Screw
46522	7802	Leg
25123	—	Pitman Adjusting Block
558E	693	" " Screw
1570E	693	" " " Nut
25075	695	" " " Washer
25074	7802	Pitman (adjustable) complete with two each 558E, 1570E, 25075 and 25123
7958	695	Pitman Pin
11742	695	" Washer
25082	7802	Treadle
297C	692	" Screw Centre
46629	—	" " " 297c with 1507J
1507J	693	" " " Nut
25086	7802	Wrench for 1507
25287	—	Stand (iron work) rocking treadle, complete, Nos. 7958, 11742, 25074, 25082, 25086, 25133, 46533, two 46522 and four 748E

TRIMMINGS FOR END AND BACK LEAF TABLE

NO.	PLATE	NAME
25001	7802	Back Leaf Bracket with two wood screws 1 in. No. 10
25002	7802	Back Leaf Scroll Bracket with $\frac{3}{4}$ in. No. 9 and two 1 in. No. 12 wood screws
25003	7802	Back Leaf Sliding Hinge, Nos. 25149, three 25151 and six wood screws $\frac{3}{4}$ in. No. 8
25151	7802	Back Leaf Sliding Hinge Plate
25149	7802	" " " " Rod
25057	7802	End Leaf Support complete, Nos. 25143, 25168, 25169 and two wood screws $\frac{5}{8}$ in. No. 7
25168	680	End Leaf Support Bracket
25060	7802	" " " " Button with wood screw $1\frac{1}{2}$ in. No. 12 R. H. B.
25169	—	End Leaf Support Lever
25143	695	" " " " Hinge Pin
25070	695	Machine Cushion Tack (rubber)

OBSOLETE PARTS

NO.	PLATE	NAME
*5807	—	Arm for 42-1 Machine, use 5453
*13019	—	" " 42-2 and 42-4 Machines
*4381	—	" with 4448 and 4449, for 42-3 Machine, use 5819
6107	696	Arm Shaft for 5977 for 42-8 Machine
6109	696	" " " 3011 for 42-8 Machine
2007	683	" Spool Pin, use 5811
5763	696	Face Plate for 42-3 Machine
5901	—	" " " 42-1 Machine, use 5808
5994	679	Feed Bar for 42-4 Machine
5903	—	" Dog (double) for canvas work, distance between rows $\frac{1}{4}$ in., for 42-2 Machine
5803	694	Feed Dog for 42-4 Machine
5995	688	" " " leather (8 teeth) for 42-4 Machine
58E	691	Feed Regulator Hinge Screw
5998	679	" Lifting Rock Shaft Crank with 1813 and two 172E, for 42-4 Machine
172E	691	Feed Lifting Rock Shaft Crank Clamping Screw for 5998
3130	682	Guide Bar Driving Crank with 1862 and 3131, for 42-8 Machine
626C	693	Guide Bar Lifting Bracket Guide Screw Stud for 42-8 Machine
4807	679	Lifting Lever for 4812
4812	—	" " 4807 with 574D, 1528J, 4808 and 5806, for 42-3 Machine
4808	679	Lifting Lever Adjusting Block
5806	686	" " " " Hinge Pin
574D	692	" " " " Thumb Screw
1528J	693	Lifting Lever Adjusting Block Thumb Screw Nut
5822	676	Lifting Lever Adjusting Slide Block for 42-3 Machine
266D	676	Lifting Lever Adjusting Slide Block Thumb Screw for 42-3 Machine
248D	676	Lifting Lever Adjusting Slide Block Thumb Screw Stop Screw for 42-3 Machine
4809	683	Lifting Lever Hinge Stud Bracket
4811	—	" " " " " 4809 with 4810, for 42-3 Machine

NO.	PLATE	NAME
3054	678	Lifting Presser Bar for 42-8 Machine.....
2359	695	" " " Lifter for 42-8 Machine.....
1806	693	Lifting Roller and Screw for 5764, for 42-3 Machine.....
446c	691	Needle Bar Cam Roller and Stud Set Screw for 42-1 Machine.....
*3098	682	Needle Bar Connecting Link with 390e.....
56847	—	" " " " 3098 with 15472, for 42-8 Machine.....
2305	695	Needle Bar Connecting Stud with 155c, for 42-8 Machine, use 15472.....
5914	677	Oscillating Rock Shaft.....
5915	—	" Shaft for 42-1 to 42-3 and 42-8 Machines.....
455c	692	Oscillating Shaft Collar Set Screw.....
5919	682	" Crank with 1518E and 1878.....
1878	—	Oscillating Shaft Crank Roller and Screw Stud.....
1518E	693	Oscillating Shaft Crank Roller and Screw Stud Nut.....
2062	681	Presser Bar Lifter for 42-1, 42-2 and 42-4 Machines, use 5990.....
6535	—	Roller Arm for 5964.....
3223	—	" " Bracket for 5964.....
5927	684	Shuttle Bobbin for 5926, use 5810.....
5929	684	Shuttle Bobbin Case complete, Nos. 591E, 592E, 5930 to 5932, 5935 and two 5933, use 5784.....
		Nos. 5930 TO 5932 FOR 5929
5930	684	Shuttle Bobbin Case Latch.....
5931	684	" " " " Spring.....
5932	684	" " " Position Finger.....
12093	685	" Cylinder.....
56514	—	" " 12093 with 773c and 12095.....
12095	685	Shuttle Tension Spring.....
5751	685	" (cylinder) 2½ in. diam., for 42-4 Machine, Nos. 8162, 12000, 14535 and 56514, use 8189.....
5936	—	Shuttle Driver for 42-1 to 42-3 and 42-8 Machines.....
5753	—	Shuttle Driver for 42-4 Machine.....
2049	686	" " Pin for 42-4 Machine.....

NO.	PLATE	NAME
5937	—	Shuttle Race complete for 42-1 to 42-3 and 42-8 Machines, Nos. 741b, 5938 to 5942 and two each 219b, 399b and 5965, use 5972.....
5754	677	Shuttle Race complete for 42-4 Machine, Nos. 741b, 5755, 5756, 5760, 5938, 5939 and two each 219b, 5790 and 5965, use 5841.....
5755	—	Shuttle Race Body for 5754.....
5940	—	" " " " 5937.....
5941	677	" " Bridge for 5937.....
399b	—	" " Screw for 5937.....
5760	683	" " Cap (left) for 5754.....
5756	683	" " " (right) for 5754.....
5790	686	" " " Dowel Pin for 5754, obsolete.....
129E	691	Shuttle Race Frame Clamping Screw.....
145b	691	" " Screw.....
240E	691	" " Slide Spring Screw.....
5926	—	Shuttle, 2½ in. diam., with 5927, for 42-1 to 42-3 and 42-8 Machines, use 5783..
2102	685	Tension Disc.....
600c	—	" Screw Stud.....
5985	—	" Wheel, use 5795.....
*5986	—	" " Flange.....
5987	—	" " Hub.....
5988	—	Tension complete (wheel) Nos. 817c, 1560c, 2103, 5985 and two each 5983 and 5984, use 5797.....
5769	686	Thread Eyelet (side of arm).....
5799	686	" Guard for 5763.....
2112	—	" Retaining Disc with 2113 for 2111
2113	—	" " " Steady Pin for 2112
2114	—	" " Spring for 2111.....
2115	—	" " Stud for 2111.....
460c	—	" " Set Screw.....
2111	—	Thread Retainer complete, Nos. 2112, 2114 and 2115.....
5765	679	Thread Take-up Lever with 1819, for 42-3 Machine.....
76c	691	Thread Take-up Lever Hinge Screw.....
2124	686	" " Spring, use 5991.....
5775	689	Throat Plate for 5774, use 5851.....
5802	689	" " " carpet mitres, for 5774, use 5854.....

OBSOLETE PARTS

NO.	PLATE	NAME
5813	694	Throat Plate for 5812, use 5867
5948	—	“ “ “ 5903
5949	687	“ “ “ 5904, use 5898
5766	679	Vibrating Presser for 42-3 Machine
5829	675	“ “ “ 42-3 Machine, use 5886
5782	679	Vibrating Presser with foot off-set to the right
602d	691	Vibrating Presser Bar Hinge Cap Screw for 42-8 Machine
3135	680	Vibrating Presser Bar Lifting Bell Crank for 42-8 Machine
602d	691	Vibrating Presser Bar Lifting Bell Crank Hinge Cap Screw for 42-8 Machine
5767	683	Vibrating Presser Guide Bracket for 42-3 Machine
5768	683	Vibrating Presser Hinge Bracket with 453c, for 42-3 Machine
5798	682	Vibrating Presser Spring for 42-3 Machine

NUMERICAL LIST OF PARTS

NUMERICAL LIST OF PARTS

NO. PLATE	NAME
35D 7801	Bobbin Winder Stop Latch Hinge Screw for 27648 and 27649.....
46D 691	Bobbin Winder Frame Hinge Screw for 5762 and 5974.....
58E 691	Feed Regulator Hinge Screw, obsolete..
76D 691	Lifting Lever Connecting Rod Joint Hinge Screw for 5874 and 5877.....
76c 691	Thread Take-up Lever Hinge Screw, obsolete.....
123E 691	Arm Screw.....
129E 691	Shuttle Race Frame Clamping Screw, obsolete.....
135D 691	Oil Cup Screw.....
136F 691	Driving Flange Latch Hinge Screw for 5993.....
138B 3583	Thread Unwinder Spool Rest Set Screw for 41451.....
138B 3583	Thread Unwinder Thread Guard Rod Set Screw for 27557.....
141D 3636	Shuttle Race Screw.....
144D 691	Arm Shaft Screw.....
145D 691	Shuttle Race Screw, obsolete.....
155c 3583	Bobbin Winder Pulley Set Screw for 41443
155c 691	Needle Bar Connecting Stud Set Screw for 2052, 2305, 3147 and 15472.....
157J 691	Feed Lifting Rock Shaft Crank Clamping Screw for 3166.....
157J 691	Feed Lifting Rock Shaft Crank Fork Clamping Screw for 5997.....
158E 691	Crank Connecting Rod Cap Screw for 5969
159D 691	Bobbin Winder Bracket Screw for 5762 and 5974.....
164D 691	Face Plate Screw for 42-1 to 42-4 Machines.....
172E 691	Feed Lifting Rock Shaft Crank Clamping Screw for 5998, obsolete.....
175D 691	Face Plate Screw for 42-8 Machine.....
175E 691	Needle Bar Cam Clamping Screw for 5457
176D 3583	Bobbin Winder Tripping Arm Clamping Screw for 41447.....
176D 691	Roller Arm Lock Spring Screw for 5964..

NUMERICAL LIST OF PARTS

NO.	PLATE	NAME
178E	691	Bell Crank Bracket Screw for 5873, 5874, 5876 and 5877
178c	691	Needle Bar Cam Guide Screw for 42-1 Machine
180D	691	Lifting Lever Hinge Bracket Screw for 42-3 Machine
190D	691	Bobbin Winder Spring Screw for 5762 and 5974
190D	691	Corder Cord Guide Screw for 28329
190D	691	Oscillating Shaft Crank Roller Cap Screw for 1885
190D	691	Presser Foot Screw for 42-1, 42-2 and 42-4 Machines
190D	691	Roller Presser Screw for 42-1 and 42-4 Machines
190D	691	Vibrating Presser Guide Bracket Screw for 42-3 Machine
190D	691	Welt Gauge Cord Guide Screw for 35094
191c	691	Feed Dog Screw
191F	691	Vibrating Presser Foot Screw for 5886
193F	691	Binder Folder Screw for 28340
193D	691	Lifting Presser Foot Screw for 42-8 Machine
196F	676	Needle Clamp Screw for 4265
207D	691	Lifting Lever Hinge Stud Screw for 42-3 Machine
211D	692	Oil Cup Pad Screw for 5781
212D	691	Vibrating Presser Hinge Bracket Cap Screw for 42-3 Machine
217F	691	Vibrating Presser Foot Screw for 42-8 Machine
219D	691	Shuttle Race Cap Screw for 5754, 5937 and 5972
219D	691	Shuttle Race Cap Screw (large) for 8193
233D	1380	Binder Ribbon Tension Screw for 28340
233D	691	Face Plate Thread Guard Screw for 8179 and 8180
233D	691	Thread Take-up Spring Regulator Plate Screw for 8178 to 8180 and 8182
233D	691	Vibrating Presser Spring Screw for 42-3 Machine
240E	691	Shuttle Race Slide Spring Screw, obsolete
248D	676	Lifting Lever Adjusting Slide Block Thumb Screw Stop Screw for 42-3 Machine, obsolete
262J	692	Pressure Regulating Thumb Screw

NUMERICAL LIST OF PARTS

NO.	PLATE	NAME
266D	676	Lifting Lever Adjusting Slide Block Thumb Screw for 42-3 Machine, obsolete
286D	692	Arm Side Cover Thumb Screw
286D	5807	Binder Guide Thumb Screw for 36344, 120247 and 120248
290E	692	Lifter Presser Bar Screw Bushing for 42-3 Machine
290E	692	Needle Bar Screw Bushing for 42-1 to 42-4 Machines
290E	692	Presser Bar Screw Bushing for 42-1, 42-2 and 42-4 Machines
297c	692	Band Wheel Crank Screw Centre for 46629
297c	692	Treadle Screw Centre for 46629
304c	692	Feed Lifting Rock Shaft Screw Centre for 42-1 to 42-3 Machines
304c	692	Feed Rock Shaft Screw Centre
313c	692	" Bar Screw Centre
316F	692	Roller Arm Bracket Screw Centre for 5964
330D	692	Driving Flange Spring Screw for 5993
330D	3583	Thread Unwinder Thread Guard Set Screw for 60609
333D	692	Bobbin Winder Friction Wheel Washer Screw for 5809 and 5957
337D	692	Vibrating Presser Bar Spring Screw for 56844
356c	693	Rock Shaft Knee Arm Hub Set Screw for 2766
356c	693	Rock Shaft Knee Plate Set Screw for 2767
356c	693	" " Lifting Bracket Hook Set Screw for 6337
356c	693	Rock Shaft Lifting Bracket Set Screw for 6337
356c	693	Rock Shaft Stop Dog Set Screw for 2770
375c	692	Feed Connecting Link Hinge Screw
375c	692	" Forked Connection Hinge Screw
377c	692	Needle Bar Connecting Link Hinge Screw for 42-2 to 42-4 Machines
390c	692	Needle Bar Connecting Link Adjusting Screw for 3098 and 4898
399D	—	Shuttle Race Bridge Screw for 5937, obsolete
401E	3643	Throat Plate Needle Hole Strip Screw for 5851, 5854, 5867, 5881, 5898 and 8199
404D	692	Guide Bar Lifting Bracket Screw for 4730
418E	693	Bobbin Winder Tension Screw Stud for 27308

NO.	PLATE	NAME
418E	693	Thread Retainer Screw Stud for 5989....
435c	691	Driving Flange Set Screw for 5978.....
440F	691	Roller Arm Adjusting Screw for 5964....
446c	691	Feed Cam Set Screw for 3032.....
446c	691	Needle Bar Cam Roller and Stud Set Screw for 42-1 Machine, obsolete.....
446c	691	Thread Take-up Cam Set Screw for 5757, 5764, 5817 and 5952.....
448c	691	Arm Shaft Bushing (back) Set Screw....
448c	691	Balance Wheel Set Screw for 3011.....
448c	691	Lifting Lever Pin Set Screw for 4724....
448c	691	Tension Screw Stud Set Screw for 8178 to 8180 and 8182.....
448c	691	Thread Take-up Cam Set Screw for 13017
453c	692	Feed Rock Shaft Crank Set Screw for 5913
453c	692	Lifting Presser Bar Lifting Bracket Set Screw for 5827.....
453c	692	Needle Bar Cam Roller and Stud Set Screw for 5952.....
453c	692	Oscillating Shaft Collar Set Screw for 5917
453c	692	“ “ Crank Set Screw for 5967 and 6000.....
453c	692	Presser Bar Lifting Bracket Set Screw for 5608 and 5612.....
453c	692	Vibrating Presser Hinge Bracket Set Screw for 5830.....
455c	692	Oscillating Shaft Collar Set Screw, obsolete
458c	3583	Bobbin Winder Frame Hinge Pin Set Screw for 41439.....
460c	—	Thread Retaining Stud Set Screw, obsolete
462c	3643	Feed Rock Shaft Crank Set Screw for 3043
558E	693	Pitman Adjusting Screw for 25074.....
566c	692	Crank Connecting Rod Hinge Screw....
574D	692	Lifting Lever Adjusting Block Thumb Screw for 4812, obsolete.....
575E	3636	Shuttle Race Frame Clamping Screw....
590D	692	“ Cylinder Latch Spring Screw for 8162.....
591F	692	Shuttle Tension Regulating Screw for 5784 and 5929.....
592E	692	Shuttle Bobbin Case Latch Stop Screw for 5784 and 5929.....
598c	691	Lifting Presser Bar Lifter Screw for 42-8 Machine.....
600c	—	Tension Screw Stud, obsolete.....
602D	691	Vibrating Presser Bar Hinge Cap Screw for 42-8 Machine, obsolete.....

NO.	PLATE	NAME
602D	691	Vibrating Presser Bar Lifting Bell Crank Hinge Cap Screw for 42-8 Machine, obsolete.....
626c	693	Guide Bar Lifting Bracket Guide Screw Stud for 42-8 Machine, obsolete.....
634D	692	Roller Screw for 1875.....
635c	692	Oscillating Rock Shaft Hinge Pin Screw Bearing for 8163.....
641E	691	Lifting Presser Bar Bracket Clamping Screw for 3133.....
651D	692	Needle Clamp Thread Guide Screw for 4803 and 4865.....
671D	5807	Binder Edge Guide Thumb Screw for 36344.....
689c	691	Lifting Presser Bar Lifter Screw for 42-3 Machine.....
689c	691	Presser Bar Lifter Screw for 42-1, 42-2 and 42-4 Machines.....
690E	691	Guide Bar Driving Crank Wedge Adjust- ing Screw for 42-8 Machine.....
725E	3636	Shuttle Race Slide Spring Screw for 5946
741D	691	“ “ Back Spring Screw for 5754, 5937 and 5972.....
742F	692	Throat Plate Screw.....
747D	3641	Guide Thumb Screw.....
748E	7801	Brace Screw for 25287.....
773F	692	Shuttle Tension Regulating Screw for 8194 and 56514.....
802D	691	Lifting Lever Hinge Screw for 5873, 5874, 5876 and 5877.....
808F	691	Needle Clamp Screw for 4803.....
810D	3633	Vibrating Presser Bar Hinge Cap Screw for 4730.....
810E	3633	Vibrating Presser Bar Lifting Bell Crank Hinge Cap Screw for 4730.....
817c	693	Tension Screw Stud for 5988 and 8183..
818D	692	Feed Regulator Thumb Screw.....
828c	7801	Thread Unwinder Tension Screw Stud for 60609.....
880E	7801	Brace Section Screw for 46662.....
902E	3646	Lifting Cam Screw for 5764.....
933D	3634	Shuttle Race Back Spring Screw for 5841.
934J	3636	“ “ Cap Screw (small) for 8193.
1036c	7790	Binder Leveling Screw (back) for 36340..
1036c	7790	“ “ “ for 120242.....
1044D	7792	Corder Cord Guide Arm Hinge Screw for 28329.....

NUMERICAL LIST OF PARTS

NO.	PLATE	NAME
1044d	7792	Welt Gauge Cord Guide Arm Screw for 35094
1054c	3643	Oscillating Shaft Crank Roller Screw Stud for 1885
1068d	3646	Lifting Lever Adjusting Screw for 5825
1088c	3636	Thread Take-up Lever Hinge Screw for 8159 to 8161
1128E	3643	Feed Regulator Hinge Screw
1186E	3636	" Lifting Rock Shaft Crank Clamping Screw for 8154
1266c	3643	Binder Leveling Screw (front) for 36340
1507J	693	Band Wheel Crank Screw Centre Nut for 46629
1507J	693	Treadle Screw Centre Nut for 46629
1513J	693	Crank Connecting Rod Hinge Screw Nut
1513J	693	Feed Lifting Rock Shaft Screw Centre Nut for 42-1 to 42-3 Machines
1513J	693	Feed Rock Shaft Screw Centre Nut
1513J	693	Oscillating Rock Shaft Hinge Pin Nut for 56812
1513J	693	Oscillating Rock Shaft Hinge Pin Screw Bearing Nut for 8163
1513J	693	Oscillating Shaft Crank Roller Screw Stud Nut for 5967 and 6000
1518E	693	Feed Connecting Link Hinge Screw Nut
1518E	693	" Forked Connection Hinge Screw Nut
1518E	693	Needle Bar Connecting Link Hinge Screw Nut for 42-2 to 42-4 Machines
1518E	693	Oscillating Shaft Crank Roller and Screw Stud Nut for 5919, obsolete
1519J	693	Feed Bar Screw Centre Nut
1520E	693	Lifting Presser Bar Lifter Screw Nut for 42-3 Machine
1520E	693	Presser Bar Lifter Screw Nut for 42-1, 42-2 and 42-4 Machines
1521E	693	Lifting Lever Connecting Rod Lock Nut for 5874 and 5877
1528J	693	Lifting Lever Adjusting Block Thumb Screw Nut for 4812, obsolete
1528J	693	Roller Screw Nut for 1875
1547J	693	" Arm Adjusting Screw Nut for 5964
1547J	693	" Bracket Screw Centre Nut for 5964
1549J	693	Roller Arm Lock Spring Screw Nut for 5964
1560c	693	Tension Regulating Thumb Nut for 5988 and 8183

NUMERICAL LIST OF PARTS

NO.	PLATE	NAME
1560c	3583	Thread Unwinder Tension Regulating Thumb Nut for 60609
1562J	693	Bobbin Winder Tension Regulating Thumb Nut for 27308
1562J	693	Thread Retainer Regulating Thumb Nut for 5989
1570E	693	Pitman Adjusting Screw Nut for 25074
1620J	7801	Bobbin Winder Frame Hinge Screw Nut for 27648 and 27649
1806	693	Lifting Roller and Screw for 5764 for 42-3 Machine, obsolete
1813	693	Feed Lifting Rock Shaft Crank Roller and Stud for 3166, 5998 and 8154
1819	693	Thread Take-up Lever Roller and Stud for 5758, 5765, 5828 and 5954
1823	693	Lifting Presser Bar Bracket Roller and Stud for 3133
1860	693	Needle Bar Cam Roller and Stud for 42-4 Machine
1862	3633	Guide Bar Driving Crank Roller for 3130 and 4854
1875	-----	Roller with 634b and 1528c, for 5964
1878	-----	Oscillating Shaft Crank Roller and Screw Stud for 5919, obsolete
1885	693	Oscillating Shaft Crank Roller with 490b, 1051c and 5968, for 5967 and 6000
2002	686	Arm Dowel Pin
2007	683	" Spool Pin, obsolete, use 5811
2022	3634	Shuttle Driver Pin for 42-4 Machine
2049	686	Feed Rock Shaft Crank Pin
2049	686	Oscillating Shaft Crank Pin
2049	686	Shuttle Driver Pin for 42-1 to 42-3 and 42-8 Machines, and obsolete for 42-4 Machine
2052	683	Needle Bar Connecting Stud with 155c, for 56773
2058	680	Lifting Presser Bar for 42-3 and 42-8 Machines
2062	681	Presser Bar Lifter for 42-1, 42-2 and 42-4 Machines, obsolete, use 5990
2070	686	Lifting Presser Bar Spring Washer for 42-3 and 42-8 Machines
2070	686	Presser Bar Spring Washer for 42-1, 42-2 and 42-4 Machines
2102	685	Tension Disc, obsolete
2102	3583	Thread Unwinder Tension Disc for 60609
2103	685	Tension Spring for 5797 and 5988

NO.	PLATE	NAME
2103	3583	Thread Unwinder Tension Spring for 60609.....
2105	686	Tension Thread Guard for 8173, 8174, 8177 and 8181.....
2106	7801	Bobbin Winder Tension Thread Guide for 27308.....
2107	686	Face Plate Thread Guard for 8179 and 8180.....
2108	686	Face Plate Thread Guard for 8179.....
2111	—	Thread Retainer complete, Nos. 2112, 2114 and 2115, obsolete.....
2112	—	Thread Retaining Disc with 2113, for 2111, obsolete.....
2113	—	Thread Retaining Disc Steady Pin for 2112, obsolete.....
2114	—	Thread Retaining Spring for 2111, obsolete.....
2115	—	“ “ Stud for 2111, obsolete.....
2117	695	Band Wheel Crank Pin for 25133.....
2124	686	Thread Take-up Spring, obsolete, use 5991.....
2127	686	“ “ “ Regulator Plate for 8178 to 8180 and 8182.....
2205	695	Roller Arm Lock Spring for 5964.....
2206	—	“ “ Bracket for 5964.....
2269	3583	Bobbin Winder Stop Latch Pin for 41448.....
2269	686	Vibrating Presser Stop Pin for 42-3 Machine.....
2305	695	Needle Bar Connecting Stud with 155c, for 42-8 Machine, obsolete, use 15472..
2359	695	Lifting Presser Bar Lifter for 42-8 Machine, obsolete.....
2361	3633	Vibrating Presser Bar Hinge Bracket for 56752.....
2362	3633	Vibrating Presser Bar Hinge Bracket Rivet for 56752.....
2455	685	Bobbin Winder Tension Disc for 27308.....
2455	685	Thread Retainer Disc for 5989.....
2653	3646	Lifting Lever Adjusting Screw Head Rivet for 5825.....
Nos. 2765 TO 2767 FOR 2768		
2765	3628	Rock Shaft Knee Arm.....
2766	3628	“ “ “ “ Hub with 356c....
2767	3628	“ “ “ “ Plate with 356c.....
2768	—	Rock Shaft Knee Arm complete for 5773 and 5875, Nos. 2765 to 2767.....
2770	3628	Rock Shaft Stop Dog with 356c, for 5773 and 5875.....

NO.	PLATE	NAME
2778	3628	Rock Shaft Lifting Bracket Hook for 5875.....
3005	678	Arm Shaft Bushing (back).....
3011	696	Balance Wheel (two speed) 3 in. and 5 in. pulleys, with two 448c, for 6109 and 6178.....
3012	683	Thread Take-up Cam Pin.....
3016	679	Bed Hinge complete for 5900 and 5992, Nos. 3017, 3018 and 3020.....
3017	—	Bed Hinge (half butt) for 5900 and 5992, for 3016.....
3018	—	Bed Hinge (half butt) for wood table, for 3016.....
3020	683	Bed Hinge Pin for 3016.....
3021	686	“ “ Rivet for 5900 and 5992.....
3032	678	Feed Cam with 446c.....
3033	681	“ Connecting Link.....
3037	3642	“ Forked Connection for 42-4 and 42-8 Machines.....
3039	681	Feed Regulator.....
3041	—	Feed Rock Shaft complete for 42-4 and 42-8 Machines, Nos. 3042 and 3043....
3042	3628	Feed Rock Shaft for 3041.....
3043	682	“ “ “ Crank with 462c, for 3041.....
*3045	681	Needle Bar Connecting Link for 56773 and 56815.....
3052	678	Oscillating Rock Shaft Hinge Pin for 56812.....
3054	678	Presser Bar for 42-1, 42-2 and 42-4 Machines.....
3054	678	Lifting Presser Bar for 42-8 Machine, obsolete.....
3056	678	Lifting Presser Bar Spring for 42-3 Machine.....
3056	678	Presser Bar Spring for 42-2 and 42-4 Machines.....
3094	686	Guide Bar Driving Crank Wedge for 42-8 Machine.....
*3098	682	Needle Bar Connecting Link with 390E, for 56847, obsolete.....
3100	679	Lifting Presser Bar Spring for 42-8 Machine.....
3126	680	Guide Bar for 56752.....
3130	682	“ “ Driving Crank with 1862 and 3131, for 42-8 Machine, obsolete.....
3131	3633	Guide Bar Driving Crank Roller Cap for 3130 and 4854.....

NO.	PLATE	NAME
3133	680	Lifting Presser Bar Bracket with 641e and 1823, for 42-8 Machine.....
3134	3633	Vibrating Presser Bar for 4730.....
3135	680	" " " Lifting Bell Crank for 42-8 Machine, obsolete.....
3137	3633	Vibrating Presser Bar Spring for 56844..
3146	686	Lifting Lever Hinge Stud Screw Washer for 42-3 Machine.....
3147	3646	Needle Bar Connecting Stud with 155c, for 56815.....
3166	682	Feed Lifting Rock Shaft Crank with 157j and 1813, for 42-1 to 42-3 (for 5909) and 42-8 Machines.....
3223	—	Roller Arm Bracket for 5964, obsolete....
4264	680	Needle Bar for 42-8 Machine.....
4265	686	" Clamp with 196e, for 4865.....
4266	686	" " Thread Guide for 4865....
*4287	—	Arm with 4448 and 4449, for 42-2 Machine
4288	678	" Side Cover.....
4347	3637	Wrench for 1513 and 1518 (Accessories)..
*4349	—	Crank Connecting Rod Cap for 5969....
*4381	—	Arm with 4448 and 4449, for 42-3 Machine, obsolete, use 5819.....
4448	695	Arm Oil Tube for intermediate bearing for 4287, 4381, 5453, 5801, 5819 and 8195.....
*4449	—	Arm Shaft Bushing (front) for 4287, 4381, 5453, 5801, 5819 and 8195.....
4723	683	Guide Bar Lifting Bracket for 4730.....
4724	3638	Lifting Lever with 448c, for 5874 and 5877
4725	695	" Presser Bar Lifting Bracket for 42-8 Machine.....
4726	695	Lifting Presser Bar Lifting Bracket Guide Pin for 42-8 Machine.....
4727	695	Lifting Lever Pin for 5874 and 5877.....
4728	3638	" " Connecting Rod for 5874 and 5877.....
4730	—	Guide Bar complete for 42-8 Machine, Nos. 810d, 810e, 3134, 4723, 4897, 56844 and three 404d.....
4784	3583	Bobbin Winder Frame Oil Pad for 41448
4802	686	Needle Clamp Thread Guide for 4803....
4803	686	Needle Clamp complete for 42-1 to 42-4 Machines, Nos. 651d, 808f and 4802..
4807	679	Lifting Lever for 4812, obsolete.....
4808	679	" " Adjusting Block for 4812, obsolete.....

NO.	PLATE	NAME
4809	683	Lifting Lever Hinge Stud Bracket for 4811, obsolete.....
4810	683	Lifting Lever Hinge Stud for 4811 and 5836.....
4811	—	Lifting Lever Hinge Stud Bracket 4809 with 4810, for 42-3 Machine, obsolete
4812	—	Lifting Lever 4807 with 574d, 1528j, 4808 and 5806, for 42-3 Machine, obsolete..
4822	680	Wrench for 1528, 1547 and 1549 (Accessories).....
4854	3633	Guide Bar Driving Crank with 1862 and 3131, for 42-8 Machine.....
4855	3641	Lifting Presser Bar Lifter for 42-8 Machine.....
4865	3643	Needle Clamp complete for 42-8 Machine, Nos. 651d, 4265 and 4266.....
4897	3633	Vibrating Presser Bar Lifting Bell Crank for 4730.....
*4898	3633	Needle Bar Connecting Link with 390c, for 56764.....
*5453	—	Arm with 4448 and 4449, for 42-1 Machine.....
5457	681	Needle Bar Cam with two 175e, for 42-1 Machine.....
5458	681	Needle Bar Cam Guide for 42-1 Machine.
5465	678	" " for 42-1 to 42-4 Machines....
5599	3638	Bell Crank Bracket for 13253.....
5601	3641	" " Hinge Pin for 13253.....
5607	3642	Lifting Lever for 5873 and 5876.....
5608	679	Presser Bar Lifting Bracket with 453, for 42-2 and 42-4 Machines.....
5612	678	Presser Bar Lifting Bracket with 453c, for 42-1 Machine.....
5614	679	Lifting Lever Connecting Rod for 5873 and 5876.....
5735	3641	Bell Crank Spring for 5872.....
5751	685	Shuttle (cylinder) 2 1/2 in. diam., for 42-4 Machine, Nos. 8162, 12000, 14535 and 56514, obsolete, use 8189.....
5752	685	Shuttle Frame for 8162.....
5753	—	" Driver for 42-4 Machine, obsolete
5754	677	Shuttle Race complete for 42-4 Machine, Nos. 741d, 5755, 5756, 5760, 5938, 5939 and two each 219d, 5790 and 5965, obsolete, use 5841.....
5755	—	Shuttle Race Body for 5754, obsolete....

NO.	PLATE	NAME
5756	683	Shuttle Race Cap (right) for 5754, obsolete.
5757	678	Thread Take-up Cam 8185 with 446c, for 42-4 Machine.
*5758	678	Thread Take-up Lever with 1819, for 8159
5759	688	Throat Plate for 5855 and 13252.
5760	683	Shuttle Race Cap (left) for 5754, obsolete
5761	3638	Bobbin Winder Spindle for 5809.
5762	3638	Bobbin Winder complete for 42-4 Machine, Nos. 46b, 190b, 5809, 5958 and 11114.
5763	696	Face Plate for 42-3 Machine, obsolete.
5764	680	Thread Take-up Cam with 446c, 902E and 5826, for 42-3 Machine.

Nos. 5765 TO 5768 FOR 42-3 MACHINE, OBSOLETE

5765	679	Thread Take-up Lever with 1819
5766	679	Vibrating Presser
5767	683	" " Guide Bracket
5768	683	" " Hinge Bracket with 453c.
5769	686	Thread Eyelet (side of arm) obsolete.
5769	3583	Thread Unwinder Tension Thread Eyelet for 60609.
5772	3628	Rock Shaft for 5773 and 5875.
5773	3628	Rock Shaft complete for 5873 and 5874, Nos. 2768, 2770, 5772, 6337, 12243 and two 7539.
5774	689	Feed Dog, 12 teeth, for 42-2 and 42-3 Machines.
5775	689	Throat Plate for 5774, obsolete, use 5851
5776	688	Feed Dog, for buff wheels, for 42-2 Machine, for 28321 for 42-3 Machine and for 120247 and 120248 for 42-8 Machine
5777	688	Throat Plate for 5776 for 42-2 Machine, and for 120247 and 120248 for 42-8 Machine.

Nos. 5778 TO 5780 FOR 5781

5778	696	Oil Cup.
5779	695	" " Pad (felt).
5780	695	" " Thread Eyelet.
5781	—	Oil Cup complete, Nos. 211b, 5778 to 5780 and 7071.
5782	679	Vibrating Presser with foot offset to the right, obsolete.

NO.	PLATE	NAME
5783	—	Shuttle, 2½ in. diam., Nos. 5784, 5810 and 5934, for 42-1 to 42-3 and 42-8 Machines.
5784	684	Shuttle Bobbin Case complete for 5783, Nos. 591F, 592E, 5785, 5789, 5838, 5933 and 5935.
5785	—	Shuttle Bobbin Case Hinge for 5784, Nos. 5786 to 5788.
		Nos. 5786 TO 5788 FOR 5785
5786	684	Shuttle Bobbin Case Latch.
5787	684	" " " " Lever.
5788	684	" " " " " Fulcrum Pin.
5789	684	Shuttle Bobbin Case Position Finger for 5784.
5790	686	Shuttle Race Cap Dowel Pin for 5754, obsolete.
5791	696	Face Plate for 8174.
5795	686	Tension Wheel with 5796, for 5797.
*5796	—	" " Flange for 5795.
5797	—	Tension complete (wheel) for 8178 to 8180 and 8182, Nos. 2103, 5795, 8183 and two each 5983 and 5984.
5798	682	Vibrating Presser Spring for 42-3 Machine, obsolete.
5799	686	Thread Guard for 5763, obsolete.
5800	687	Feed Dog, for leather, 20 teeth, for 42-1 Machine.
*5801	—	Arm with 4448 and 4449, for 42-8 Machine
5802	689	Throat Plate, for carpet mitres, for 5774, obsolete, use 5854.
5803	694	Feed Dog for 42-4 Machine, obsolete.
5804	694	Throat Plate for 5856.
5806	686	Lifting Lever Adjusting Block Hinge Pin for 4812, obsolete.
*5807	—	Arm for 42-1 Machine, obsolete, use 5453
5808	696	Face Plate for 8177.
5809	—	Bobbin Winder Frame complete for 5762, Nos. 333b, 5761, 5959 to 5961 and 5963
5810	684	Shuttle Bobbin (solid) for 5783.
5811	695	Arm Spool Pin and Thread Eyelet.

Nos. 5812 TO 5817 FOR 42-8 MACHINE

5812	694	Feed Dog.
5813	694	Throat Plate for 5812, obsolete, use 5867
5814	694	Vibrating Presser Foot.

NO.	PLATE	NAME
5815	3642	Feed Lifting Rock Shaft.....
5816	694	Lifting Presser Foot.....
5817	680	Thread Take-up Cam with 446e.....
*5819	—	Arm with 4448 and 4449, for 42-3 Machine
5820	675	Face Plate for 8181.....
5821	675	Lifting Lever for 5825.....
5822	676	“ “ Adjusting Slide Block for 42-3 Machine, obsolete.....
5823	676	Lifting Lever Adjusting Slide Roller for 5825.....
5824	676	Lifting Lever Adjusting Slide Roller Pin for 5825.....
5825	—	Lifting Lever complete for 42-3 Machine, Nos. 1068b, 2653, 5821, 5823, 5824, 5878 and 5879.....
5826	676	Lifting Cam for 5764.....
5827	675	“ Presser Bar Lifting Bracket with two 453c, for 42-3 Machine.....
*5828	675	Thread Take-up Lever with 1819, for 8160
5829	675	Vibrating Presser for 42-3 Machine, obsolete, use 5886.....
5830	676	Vibrating Presser Hinge Bracket with 453c, for 42-3 Machine.....
5831	676	Vibrating Presser Spring for 42-3 Machine
5832	677	Shuttle Driver for 42-1 to 42-3 and 42-8 Machines.....
5833	679	Shuttle Driver for 42-4 Machine.....
5834	3642	Oscillating Shaft for 42-1 to 42-3 and 42-8 Machines.....
5835	676	Lifting Lever Hinge Bracket for 5836.....
5836	—	Lifting Lever Hinge Bracket 5835 with 4810, for 42-3 Machine.....
5837	676	Vibrating Presser Guide Bracket for 42-3 Machine.....
5838	684	Shuttle Bobbin Case Latch Spring for 5784
5839	—	Feed Bar for 42-4 Machine.....
5840	3647	“ Dog, 12 teeth, for canvas work, for 42-4 Machine.....
5841	—	Shuttle Race complete for 42-4 Machine, Nos. 933b, 5848, 5939 and 8193..... Nos. 5842 to 5845 for 8193
5842	3634	Shuttle Race Back Spring Rest Pin.....
5843	3635	“ “ Body.....
5844	3636	“ “ Cap (left).....
5845	3636	“ “ “ (right).....
5848	3635	“ “ Back for 5841.....

NO.	PLATE	NAME
5849	—	Throat Plate Body for 5851.....
5850	3645	“ “ Needle Hole Strip for 5851..
5851	3645	Throat Plate complete for 5774 and 5893, Nos. 5849, 5850 and two 401E.....
5852	—	Throat Plate Body for 5854.....
5853	3645	“ “ Needle Hole Strip for 5854 and 5881.....
5854	3645	Throat Plate complete, for carpet mitres, for 5774 and 5893, Nos. 5852, 5853 and two 401E.....
5855	688	Feed Dog, 8 teeth (10 teeth to the inch) for leather, for 42-4 Machine.....
5856	694	Feed Dog, for cloth, for 42-4 Machine....
5865	—	Throat Plate Body for 5867.....
5866	3644	“ “ Needle Hole Strip for 5867
5867	3644	Throat Plate complete for 5812, Nos. 5865, 5866 and two 401E.....
5871	3638	Bell Crank for 13253.....
5872	3638	Bell Crank complete for 5873, 5874, 5876 and 5877, Nos. 5735 and 13253.....
5873	—	Knee Lifter complete (power table) for 42-1 to 42-4 Machines, Nos. 802b, 5607, 5614, 5773, 5872 and two 178E.....
5874	—	Knee Lifter complete (power table) for 42-8 Machine, Nos. 76b, 802b, 1521E, 4724, 4727, 4728, 5773, 5872, 12416 and two 178E.....
5875	—	Rock Shaft complete for 5876 and 5877, Nos. 2768, 2770, 2778, 5772, 6337 and two 7539.....
5876	—	Knee Lifter complete (stand) for 42-1 to 42-4 Machines, Nos. 802b, 5607, 5614, 5872, 5875 and two 178E.....
5877	—	Knee Lifter complete (stand) for 42-8 Machine, Nos. 76b, 802b, 1521E, 4724, 4727, 4728, 5872, 5875, 12416 and two 178E.....
5878	3646	Lifting Lever Adjusting Screw Head for 5825.....
5879	3646	Lifting Lever Adjusting Slide for 5825..
5880	—	Throat Plate Body for 5881.....
5881	3647	Throat Plate complete for 5840 and 5894, Nos. 5853, 5880 and two 401E.....
5885	3646	Vibrating Presser Bar for 5886.....
5886	—	Vibrating Presser Bar complete for 42-3 Machine, Nos. 191F, 5885 and 5887....
5887	3646	Vibrating Presser Foot for 5886.....

NO.	PLATE	NAME
5888	3648	Feed Dog, 11 teeth (10 teeth to the inch) for 42-8 Machine and for 28340 for the same machine.....
5889	3648	Throat Plate for 5888 and 8157 for 42-8 Machine.....
5890	7793	Vibrating Presser Foot for 120247 and 120248 for 42-8 Machine.....
5893	7806	Feed Dog, 21 teeth, for 42-2 and 42-3 Machines.....
5894	7806	Feed Dog, 22 teeth, for 42-4 Machine...
5896	—	Throat Plate Body for 5898.....
5897	3649	" " Needle Hole Strip for 5898
5898	3649	Throat Plate complete for 5800 and 5904, Nos. 5896, 5897 and two 401E.....
*5900	—	Bed with two 3016 and six 3021, for 42-1 to 42-3 Machines.....
5901	—	Face Plate for 42-1 Machine, obsolete, use 5808.....
5902	677	Feed Bar for 42-1 to 42-3 and 42-8 Machines.....
5903	—	Feed Dog (double) for canvas work, distance between rows $\frac{1}{4}$ in., for 42-2 Machine, obsolete.....
5904	687	Feed Dog, for leather work, 12 teeth, for 42-1 Machine.....
5905	690	Feed Dog, for tent work, for 42-2 Machine
5906	690	" " " canvas work, for 42-2 Machine.....
5907	3642	Feed Forked Connection for 42-1 to 42-3 Machines.....
5908	3642	Feed Lifting Rock Shaft for 5909.....
5909	—	Feed Lifting Rock Shaft complete for 42-1 to 42-3 Machines, Nos. 3166 and 5908.....
5910	3642	Feed Rock Shaft for 5911.....
5911	—	Feed Rock Shaft complete for 42-1 to 42-3 Machines, Nos. 5910 and 5913...
5913	682	Feed Rock Shaft Crank with 453c, for 5911
5914	677	Oscillating Rock Shaft, obsolete.....
5915	—	" Shaft for 42-1 to 42-3 and 42-8 Machines, obsolete.....
5917	682	Oscillating Shaft Collar with 453c.....
5919	682	" " Crank with 1518E and 1878, obsolete.....
5920	687	Presser Foot (solid) for 42-2 Machine...
5921	689	Presser Foot (hinged) complete for 42-2 Machine, Nos. 5922 to 5924.....

NO.	PLATE	NAME
Nos. 5922 to 5924 FOR 5921		
5922	—	Presser Foot Bracket.....
5923	686	" " Plate Hinge Pin.....
5924	—	" " Plate.....
5926	—	Shuttle, 2½ in. diam., with 5927, for 42-1 to 42-3 and 42-8 Machines, obsolete, use 5783.....
5927	684	Shuttle Bobbin for 5926, obsolete, use 5810
5929	684	Shuttle Bobbin Case complete, Nos. 591E, 592E, 5930 to 5932, 5935 and two 5933, obsolete, use 5784.....
Nos. 5930 TO 5932 FOR 5929, OBSOLETE		
5930	684	Shuttle Bobbin Case Latch.....
5931	684	" " " " Spring.....
5932	684	" " " " Position Finger.....
5933	684	" " " " " Rivet for 5784 and 5929.....
5934	684	Shuttle Body for 5783.....
5935	684	" Tension Spring for 5784 and 5929
5936	—	Shuttle Driver for 42-1 to 42-3 and 42-8 Machines, obsolete.....
5937	—	Shuttle Race complete for 42-1 to 42-3 and 42-8 Machines, Nos. 741D, 5938 to 5942 and two each 219D, 399D and 5965, obsolete, use 5972.....
5938	677	Shuttle Race Back for 5754, 5937 and 5972
5939	677	" " " Spring for 5754, 5841, 5937 and 5972.....
5940	—	Shuttle Race Body for 5937, obsolete....
5941	677	" " Bridge for 5937, obsolete...
5942	677	" " Cap for 5937 and 5972.....
5943	677	" " Frame with 5944.....
5944	686	" " " Steady Pin for 5943
5945	—	" " Slide for 5946.....
5946	677	Shuttle Race Slide complete, Nos. 5945, 5947 and two 725E.....
5947	682	Shuttle Race Slide Spring for 5946.....
5948	—	Throat Plate for 5903, obsolete.....
5949	687	" " " 5904, obsolete, use 5898.
5950	690	" " " 5905.....
5951	690	" " " 5906.....
5952	678	Thread Take-up Cam with 446c and 453c, for 42-1 Machine.....
*5954	678	Thread Take-up Lever with 1819, for 8161

NO.	PLATE	NAME
5955	7806	Presser Foot (long shank) for 5774 and 5893 for 42-2 Machine
5957	—	Bobbin Winder Frame complete for 5974, Nos. 333D and 5959 to 5963
5958	680	Bobbin Winder Bracket for 5762 and 5974 Nos. 5959 to 5961 FOR 5809 AND 5957
5959	680	Bobbin Winder Frame
5960	678	" " Friction Wheel (leather)
5961	678	" " " " Washer
5962	678	" " Spindle for 5957
5963	678	" " " Flange for 5809 and 5957
5964	687	Roller Presser complete, 1½ in. roller, for 42-1 and 42-4 Machines, Nos. 176D, 440F, 1549J, 1875, 2205, 2206, 8152, two 316F and three 1547J
5965	686	Shuttle Race Back Steady Pin for 5754, 5937, 5972 and 8193
5966	—	Oscillating Shaft Crank for 5967
5967	681	Oscillating Shaft Crank complete for 42-1 to 42-3 and 42-8 Machines, Nos. 453C, 1513J, 1885 and 5966
5968	686	Oscillating Shaft Crank Roller Cap Screw Washer for 1885
5969	3642	Crank Connecting Rod with 4349 and two 158E
*5970	679	Oscillating Rock Shaft with 11165, for 8163
5971	687	Presser Foot (long shank) for 42-1 and 42-4 Machines
5972	677	Shuttle Race complete for 42-1 to 42-3 and 42-8 Machines, Nos. 741D, 5938, 5939, 5942, 5973 and two each 219D and 5965
5973	—	Shuttle Race Body for 5972
5974	680	Bobbin Winder complete for 42-1 to 42-3 and 42-8 Machines, Nos. 46D, 190D, 5957, 5958 and 11114
5975	3627	Drip Pan (stand) with four wood screws ½ in. No. 5
5976	—	Drip Pan (power table) with four wood screws ½ in. No. 5
5977	696	Balance Wheel (two speed) for 5981 Nos. 5978 to 5980 FOR 5993
5978	696	Driving Flange with two 435C

NO.	PLATE	NAME
5979	683	Driving Flange Latch
5980	683	" " Spring
5981	—	Loose Wheel Attachment complete, Nos. 5977 and 5993
5982	696	Face Plate for 8173
5983	686	Tension Washer (felt) for 5797 and 5988
5984	686	" " (steel) for 5797 and 5988
5985	—	" Wheel for 5988, obsolete, use 5795
*5986	—	" Flange, obsolete
5987	—	" Hub, obsolete
5988	—	Tension complete (wheel) Nos. 817C, 1560C, 2103, 5985 and two each 5983 and 5984, obsolete, use 5797
5989	—	Thread Retainer complete for 8178 to 8180 and 8182, Nos. 418E, 1562J, 10111 and two 2455
5990	681	Lifting Presser Bar Lifter for 42-3 Machine
5990	681	Presser Bar Lifter for 42-1, 42-2 and 42-4 Machines
5991	686	Thread Take-up Spring for 8178 to 8180 and 8182
*5992	—	Bed with two 3016 and six 3021, for 42-4 and 42-8 Machines
5993	—	Driving Flange complete for 5981, Nos. 136F, 330D and 5978 to 5980
5994	679	Feed Bar for 42-4 Machine, obsolete
5995	688	" Dog, for leather (8 teeth) for 42-4 Machine, obsolete
5996	3642	Feed Lifting Rock Shaft for 42-4 Machine
5997	679	" " " Crank Fork with 157J, for 42-4 and 42-8 Machines
5998	679	Feed Lifting Rock Shaft Crank with 1813 and two 172E, for 42-4 Machine, obsolete
5999	—	Oscillating Shaft Crank for 6000
6000	3643	Oscillating Shaft Crank complete for 42-4 Machine, Nos. 453C, 1513J, 1885 and 5999
6037	7792	Corder Cord Guide Bracket Rivet for 28329
6037	7792	Welt Gauge Cord Guide Bracket Rivet for 35094
6107	696	Arm Shaft for 5977 for 42-1 to 42-4 Machines, and obsolete for 42-8 Machine
6109	696	Arm Shaft for 3011 for 42-1 to 42-4 Machines, and obsolete for 42-8 Machine
6178	3628	Arm Shaft for 3011 for 42-8 Machine

NO.	PLATE	NAME
6179	3628	Arm Shaft for 5977 for 42-8 Machine
6337	3628	Rock Shaft Lifting Bracket with two 356c, for 5773 and 5875
6466	678	Presser Bar Spring for 42-1 Machine
6535	—	Roller Arm for 5964, obsolete
7071	695	Binder Folder Screw Washer for 28340
7071	695	Oil Cup Pad Screw Washer for 5781
7539	3628	Rock Shaft Hanger with two wood screws 1 in. No. 10, for 5773 and 5875
7958	695	Pitman Pin for 25287
8151	7806	Presser Foot for 5856
8152	—	Roller Arm for 5964
8154	—	Feed Lifting Rock Shaft Crank with 1813 and two 1186e, for 42-4 Machine
8157	3648	Feed Dog, 19 teeth (18 teeth to the inch) for 42-8 Machine
8159	—	Thread Take-up Lever 5758 with 1088c, for 42-4 Machine
8160	—	Thread Take-up Lever 5828 with 1088c, for 42-3 Machine
8161	—	Thread Take-up Lever 5954 with 1088c, for 42-1, 42-2 and 42-8 Machines
8162	—	Shuttle Frame 5752 with 590b, 11854, 12001 and 12002, for 5751 and 8189
8163	—	Oscillating Rock Shaft 5970 with 635c, 1513j and 56812
8166	680	Oscillating Shaft for 42-4 Machine
8173	—	Face Plate 5982 with 2105, for 8179
8174	—	“ “ 5791 with 2105, for 8178
8177	—	“ “ 5808 with 2105, for 8180
8178	—	Face Plate complete for 42-8 Machine, Nos. 233b, 448c, 2108, 2127, 5797, 5989, 5991 and 8174
8179	—	Face Plate complete for 42-2 and 42-4 Machines, Nos. 448c, 2107, 2127, 5797, 5989, 5991, 8173 and two 233b
8180	—	Face Plate complete for 42-1 Machine, Nos. 448c, 2107, 2127, 5797, 5989, 5991, 8177 and two 233b
8181	—	Face Plate 5820 with 2105, for 8182
8182	—	Face Plate complete for 42-3 Machine, Nos. 233b, 448c, 2127, 5797, 5989, 5991 and 8181
8183	—	Tension Screw Stud 817c with 1560c, for 5797
*8185	—	Thread Take-up Cam for 5757
8187	3634	Shuttle Cylinder for 8194

NO.	PLATE	NAME
8188	3634	Shuttle Tension Spring for 8194
8189	3634	Shuttle (cylinder) 2½ in. diam., complete, for 42-4 Machine, Nos. 8162, 8194, 12000 and 14535
*8193	—	Shuttle Race Body 5843 with 5842, 5844, 5845 and two each 219b, 934j and 5965, for 5841
8194	—	Shuttle Cylinder 8187 with 773c and 8188, for 8189
*8195	—	Arm with 4448 and 4449, for 42-4 Machine
8196	3647	Feed Dog for 42-4 Machine
8197	—	Throat Plate Body for 8199
8198	3647	“ “ Needle Hole Strip for 8199
8199	3647	Throat Plate complete for 8196, Nos. 8197, 8198 and two 401e
8879	7801	Arm Spool Pin Washer (cloth)
10141	685	Bobbin Winder Tension Spring for 27308
10141	685	Thread Retainer Spring for 5989
11114	682	Bobbin Winder Spring for 5762 and 5974
11165	695	Oscillating Rock Shaft Oil Pad for 5970
11241	7800	Bobbin Winder Spool Washer (cloth) for 27308
11742	695	Pitman Washer for 25287
11854	3634	Shuttle Cylinder Latch Spring for 8162
12000	685	“ “ Hinge Pin for 5751 and 8189
12001	685	Shuttle Cylinder Latch for 8162
12002	685	“ “ “ Pin for 8162
12093	685	“ “ for 56514, obsolete
12095	685	“ Tension Spring for 56514, obsolete
12243	3628	Rock Shaft Lifting Bracket Hook for 5773
12296	686	Thread Eyelet (side of arm)
12416	3641	Lifting Lever Connecting Rod Joint for 5874 and 5877
13017	678	Thread Take-up Cam with 448c, for 42-2 Machine
*13019	—	Arm for 42-2 and 42-4 Machines, obsolete
13252	3647	Feed Dog, 14 teeth (18 teeth to the inch) for leather, for 42-4 Machine
13253	—	Bell Crank 5871 with 5599 and 5601, for 5872
14535	685	Shuttle Bobbin for 5751 and 8189
15072	7801	Bobbin Winder Bobbin Position Pin for 27330
15472	3633	Needle Bar Connecting Stud with 155c, for 56764 and 56847

NO.	PLATE	NAME
17547	7801	Thread Unwinder Tension Thread Guard for 60609.....
Nos. 25001 to 25003 for TRIMMINGS FOR END AND BACK LEAF TABLE.		
25001	7802	Back Leaf Bracket with two wood screws 1 in. No. 10.....
25002	7802	Back Leaf Scroll Bracket with $\frac{3}{4}$ in. No. 9 and two 1 in. No. 12 wood screws..
25003	7802	Back Leaf Sliding Hinge, Nos. 25149, three 25151 and six wood screws $\frac{3}{4}$ in. No. 8.....
25010	7802	Band Wheel Crank for 25133.....
25029	695	Belt Hook for 25136.....
25057	7802	End Leaf Support complete, Nos. 25143, 25168, 25169 and two wood screws $\frac{5}{8}$ in. No. 7 (Trimnings for End and Back Leaf Table).....
25060	7802	End Leaf Support Button with wood screw $1\frac{1}{2}$ in. No. 12 R. H. B. (Trimnings for End and Back Leaf Table).....
25070	695	Machine Cushion Tack, rubber (Trimnings for End and Back Leaf Table)..
25074	7802	Pitman (adjustable) complete with two each 558E, 1570E, 25075 and 25123, for 25287.....
25075	695	Pitman Adjusting Screw Washer for 25074
25082	7802	Treadle for 25287.....
25086	7802	Wrench for 1507 for 25287.....
25123	—	Pitman Adjusting Block for 25074.....
25133	7802	Band Wheel (two speed) 10 in. and 12 in. diam., with 2117 and 25010, for 25287.....
25136	—	Belt, size $\frac{5}{16}$ in., length $62\frac{1}{2}$ in., with 25029, for 25287.....
25143	695	End Leaf Support Lever Hinge Pin for 25057.....
25149	7802	Back Leaf Sliding Hinge Rod for 25003..
25151	7802	“ “ “ “ Plate for 25003.
25168	680	End Leaf Support Bracket for 25057.....
25169	—	“ “ “ “ Lever for 25057.....
25287	—	Stand (iron work) rocking treadle, complete, Nos. 7958, 11742, 25074, 25082, 25086, 25133, 46533, two 46522 and four 748E.....
25867	7795	Guide for 42-1 and 42-2 Machines.....

NO.	PLATE	NAME
25868	3637	Guide for carpet mitres, for 42-3, 42-4 and 42-8 Machines.....
26026	3637	Screw Driver, large (Accessories).....
26485	3637	“ “ small (Accessories).....
26486	3643	Binder Ribbon Tension Pin (straight) for 28337.....
26617	3643	Binder Ribbon Tension Pin (bent) for 28337.....
26795	7792	Corder Cord Guide for 28329.....
26795	3623	Welt Gauge Cord Guide for 35094.....
26796	7792	Corder Cord Guide Arm for 28329.....
26796	3623	Welt Gauge Cord Guide Arm for 35094
26798	7792	Corder Cord Guide Bracket for 28329....
26798	3623	Welt Gauge Cord Guide Bracket for 35094
26800	7794	Piping Attachment on Shank for 42-8 Machine.....
26996	3622	Lifting Presser Foot with stitch set for 42-8 Machine.....
26997	3625	Presser Foot for 26998 for 42-1 Machine
26998	3625	Binder on Shank, for binding canvas with leather, for 42-1 and 42-3 Machines...
26999	3625	Binder on Shank, for horse carpet aprons, for 42-2 Machine.....
27000	3626	Hemmer on Shank, for canvas, for 42-8 Machine.....
27056	3637	Machine Button with wood screw $1\frac{3}{4}$ in. No. 14 R. H. B. (Accessories).....
27302	7805	Bobbin Winder Frame for 27648.....
27303	7801	“ “ “ Spring for 27648 and 27649.....
27306	7800	Bobbin Winder Spool Pin for 27308.....
27307	7800	“ “ “ Stand for 27308....
27308	7800	Bobbin Winder Spool Stand complete for 27548 and 27549, Nos. 418E, 1562A, 2106, 10141, 11241, 27306, 27307 and two each 2455 and wood screws 1 in. No. 10.....
27330	7800	Bobbin Winder Spindle with 15072, for 27649.....
27331	7800	Bobbin Winder Stop Latch for 27649....
27333	7805	“ “ Spindle for 27648.....
27334	7805	“ “ Stop Latch for 27648.....
27527	7800	“ “ Frame for 27649.....
27540	7800	“ “ Base for 27648 and 27649
27541	7800	“ “ Pulley for 27648 and 27649.....

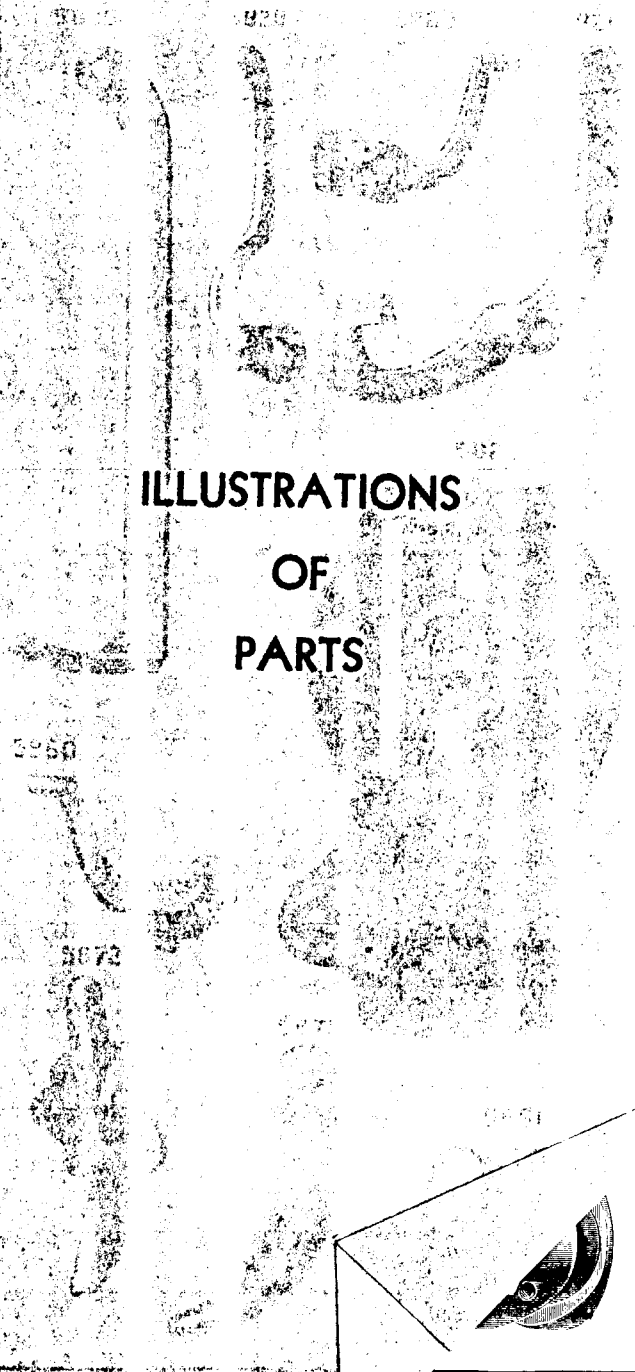
NO.	PLATE	NAME
27548	—	Bobbin Winder (swinging automatic, right hand) complete for 5810, Nos. 27308 and 27648.
27549	—	Bobbin Winder (swinging automatic, right hand) complete for 14535, Nos. 27308 and 27649.
27555	3582	Thread Unwinder Spool Pin for 41451.
27557	3582	“ “ “ Stand with 138b, for 41454.
27560	3582	Thread Unwinder Thread Guard Rod, 26 in. long, for 41454.
27648	7805	Bobbin Winder for 27548, Nos. 35d, 1620r, 27302, 27303, 27333, 27334, 27540, 27541, 50356d and two wood screws 1 in. No. 7.
27649	7800	Bobbin Winder for 27549, Nos. 35d, 1620r, 27303, 27330, 27331, 27527, 27540, 27541, 50356d and two wood screws 1 in. No. 7.
27916	3583	Bobbin Winder Brake (leather) for 41439.
28084	3583	“ “ “ Rivet for 41439.
28301	7795	Binder on Shank, for carpet matting, for 42-8 Machine.
28302	3600	Feed Dog for 28305.
28303	3600	Presser Foot for 28305.
28304	3600	Throat Plate for 28302.
28305	3600	Binder on Shank, for circular binding, for 42-1 Machine.
28308	7806	Feed Dog for 42-2 Machine.
28309	7806	Throat Plate for 28308 for 25721.
28310	3602	Presser Foot for 28311.
28311	3602	Binder (horn) on Shank for 42-1 Machine.
28312	3602	Presser Foot (grooved) for 28313.
28313	3602	Piping Attachment, for car cushions, for 42-2 Machine.
28314	7793	Lifting Presser Foot for 28316.
28315	7793	Vibrating Presser Foot for 28316.
28316	7793	Feed Dog (grooved) for covering cord with thin leather, for 42-8 Machine.
28317	7793	Throat Plate (grooved) for 28316.
28318	3604	Hemmer and Corder on Shank for 42-2 Machine.
28319	3605	Binder on Shank, for binding leather with turned edge binding of leather, for 42-8 Machine.
28320	3605	Throat Plate for 5776 for 28321.

NO.	PLATE	NAME
28321	3604	Binder on Shank, for saddle housing, for 42-3 Machine.
28322	3606	Binder on Shank, for binding carpets, for 42-3 Machine.
28328	7792	Corder Cord Guide Bed for 28329.
28329	7792	Corder (adjustable) complete, for buggy cushions, Nos. 190d, 1044d, 26795, 26796, 26798, 28328 and three 6037.
28334	1380	Binder Folder for 28340.
28335	3610	Lifting Presser Foot for 28340 and 42-8 Machine, for 120247 and 120248.
28336	—	Binder Ribbon Tension Plate for 28337.
28337	1380	Binder Ribbon Tension complete for 28340; Nos. 26617, 28336 and eight 26486.
28338	3610	Throat Plate for 5888 for 28340.
28339	3610	Vibrating Presser Foot for 28340.
28340	—	Binder (English) complete, for mattresses, for 42-8 Machine, Nos. 193e, 5888, 7071, 28334, 28335, 28337 to 28339 and two 233b.
35086	3621	Feed Dog for 35089, 35090 and 35094.
35087	3621	Presser Foot for 35089.
35088	3621	Throat Plate for 35086.
35089	3622	Welt Gauge on Shank, for inserting corded welt for upholstering, etc., for 42-1 Machine.
35090	7795	Binder on Shank, for leather, for 42-1 Machine.
35092	3623	Lifting Presser Foot for 35094.
35093	3623	Vibrating Presser Foot for 35094.
35094	3623	Welt Gauge (adjustable, hinged) for making or inserting corded welt, for 42-8 Machine, Nos. 190d, 1044d, 26795, 26796, 26798, 35141 and three 6037.
35141	3623	Welt Gauge Bed for 35094.
35923	7794	Piping Attachment for 42-3 Machine.
35924	7794	Presser Foot for 35923.
Nos. 36340 to 36343 for 36344		
36340	5807	Binder Bed with two each 1035c and 1266c.
36341	5807	“ Edge Guide.
36342	5807	“ Guide (lower).
36343	5807	“ “ (upper).
36344	5807	Binder (adjustable) complete, for leather binding, for canvas bags, leggings, etc., for 42-8 Machine, Nos. 286d, 671d and 36340 to 36343.

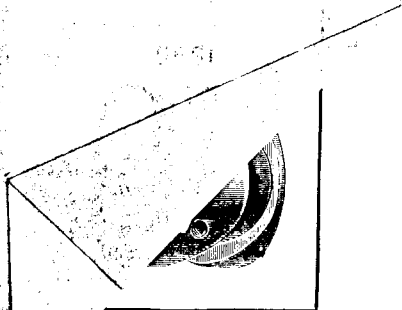
NO.	PLATE	NAME
36345	7793	Lifting Presser Foot for 36344.....
36346	7793	Vibrating Presser Foot for 36344.....
36519	7792	Presser Foot (grooved) for 28329 for 42-4 Machine.....
36999	7795	Edge Folder on Shank, for leather work, to turn the edge down, for 42-8 Machine.....
41398	3583	Bobbin Winder Bobbin Carrier Key for 41444.....
41400	3637	Machine Rest Pin, wood (Accessories)....
Nos. 41439 to 41447 for 41448		
41439	7804	Bobbin Winder Base with 458c, 27916 and two 28084.....
41440	3581	Bobbin Winder Frame.....
41441	3581	" " " Hinge Pin.....
41442	3581	" " " Spring.....
41443	3581	" " Pulley with 155c.....
41444	7804	" " Spindle with 41398.....
41445	7804	" " Stop Latch.....
41446	7804	" " " " Hinge Pin....
41447	3581	" " Tripping Arm with 176d..
41448	7804	Bobbin Winder for 41449, Nos. 2269, 41439 to 41447, two 4784 and three wood screws 1 in. No. 7.....
41449	—	Bobbin Winder (swinging automatic, right hand) complete for 14535, Nos. 41448 and 41454.....
41450	3582	Thread Unwinder Spool Rest for 41451..
41451	—	" " " " 41450 with 138n and 27555, for 41454.....
41454	3582	Thread Unwinder complete, for one large spool, for 41449, Nos. 27557, 27560, 41451, 41514, 60609 and three wood screws 1¼ in. No. 12.....
41514	3582	Thread Unwinder Spool Weight, 4 in. diam., with 41515, for 41454.....
41515	3583	Thread Unwinder Spool Weight Centre Pin for 41514.....
46522	7802	Leg for 25287.....
46528	7803	Brace Section (left) with 46629, for 46662.....
46533	7802	" 46667 with three 46629, for 25287.....
46629	—	Band Wheel Crank Screw Centre 297c with 1507j, for 46533 and 46663.....
46629	—	Treadle Screw Centre 297c with 1507j, for 46528, 46533 and 46663.....
46662	7803	Brace (sectional) complete for 25287, Nos. 46528, 46663 and three 880e.....

NO.	PLATE	NAME
46663	7803	Brace Section (right) with two 46629, for 46662.....
46667	—	Brace for 46533.....
50356b	7801	Bobbin Winder Frame Hinge Screw for 27648 and 27649.....
56514	—	Shuttle Cylinder 12093 with 773r and 12095, for 5751.....
56752	—	Guide Bar 3126 with 2361 and two 2362, for 56844.....
56764	—	Needle Bar Connecting Link 4898 with 15172, for 42-8 Machine.....
56773	—	Needle Bar Connecting Link 3045 with 2052, for 42-2 and 42-4 Machines.....
56812	—	Oscillating Rock Shaft Hinge Pin 3052 with 1513j, for 8163.....
56815	—	Needle Bar Connecting Link 3045 with 3147, for 42-3 Machine.....
56844	—	Guide Bar 56752 with 337b and 3137, for 4730.....
56847	—	Needle Bar Connecting Link 3098 with 15172, for 42-8 Machine, obsolete....
60608	3582	Thread Unwinder Thread Guard for 60609.....
60609	—	Thread Unwinder Thread Guard complete for 41454, Nos. 330b, 828c, 1560c, 2103, 5769, 17547, 60608 and two 2102.....
120099	7794	Lifting Presser Foot for 26800.....
120100	7794	Vibrating Presser Foot for 26800.....
120242	7790	Binder Bed with 1036c, for 120247 and 120248.....
120243	7791	Binder Folder (lower) for 120248.....
120244	7790	" " (upper) for 120247 and 120248.....
120245	7790	Binder Guide (centre) for 120247 and 120248.....
120246	7790	Binder Guide (lower) for 120247.....
120247	7790	Binder (adjustable) complete, to turn in upper edge only, for light or medium weight material, Nos. 286b, 120242 and 120244 to 120246.....
120248	7791	Binder (adjustable) complete, to turn in both edges, for light or medium weight material, Nos. 286b and 120242 to 120245.....
120342	3637	Oiler (copper plated) with 120343 (Accessories).....
120343	3637	Oiler Spout, 3½ in. long, for 120342.....

ILLUSTRATIONS
OF
PARTS



From the library of: Diamond Needle Corp



ILLUSTRATIONS
OF
PARTS

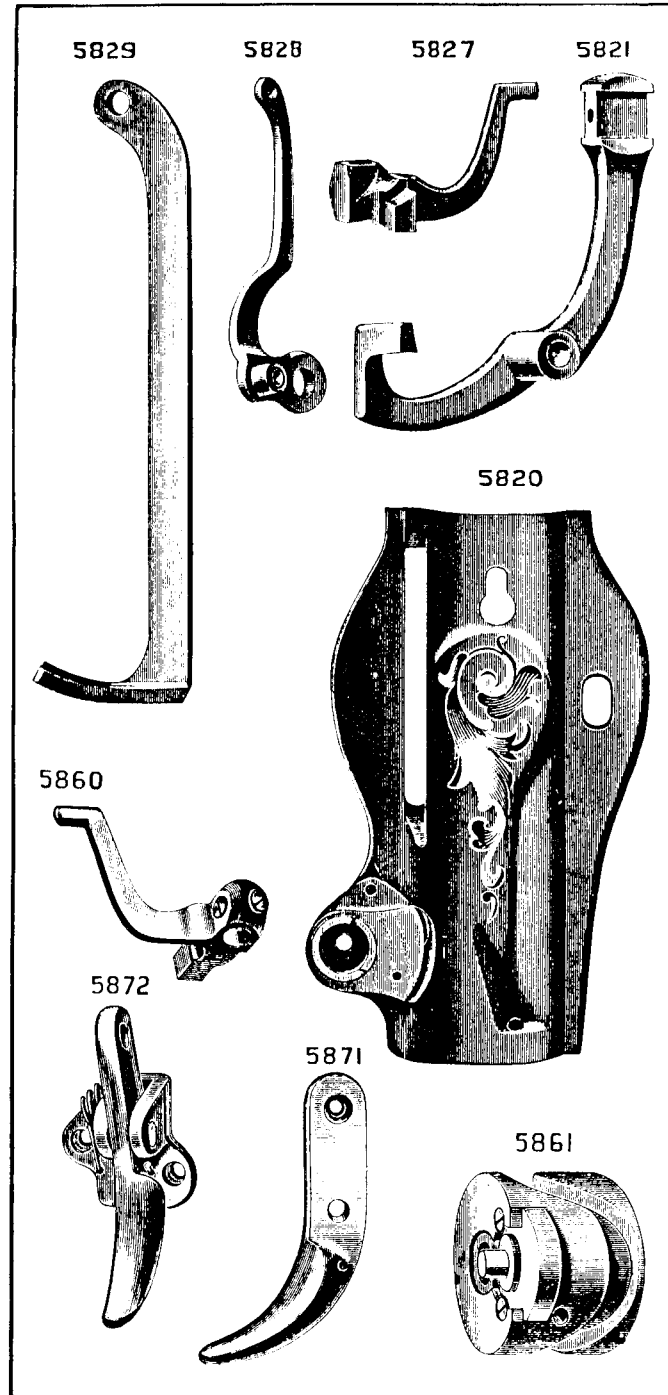


PLATE 676—FULL SIZE

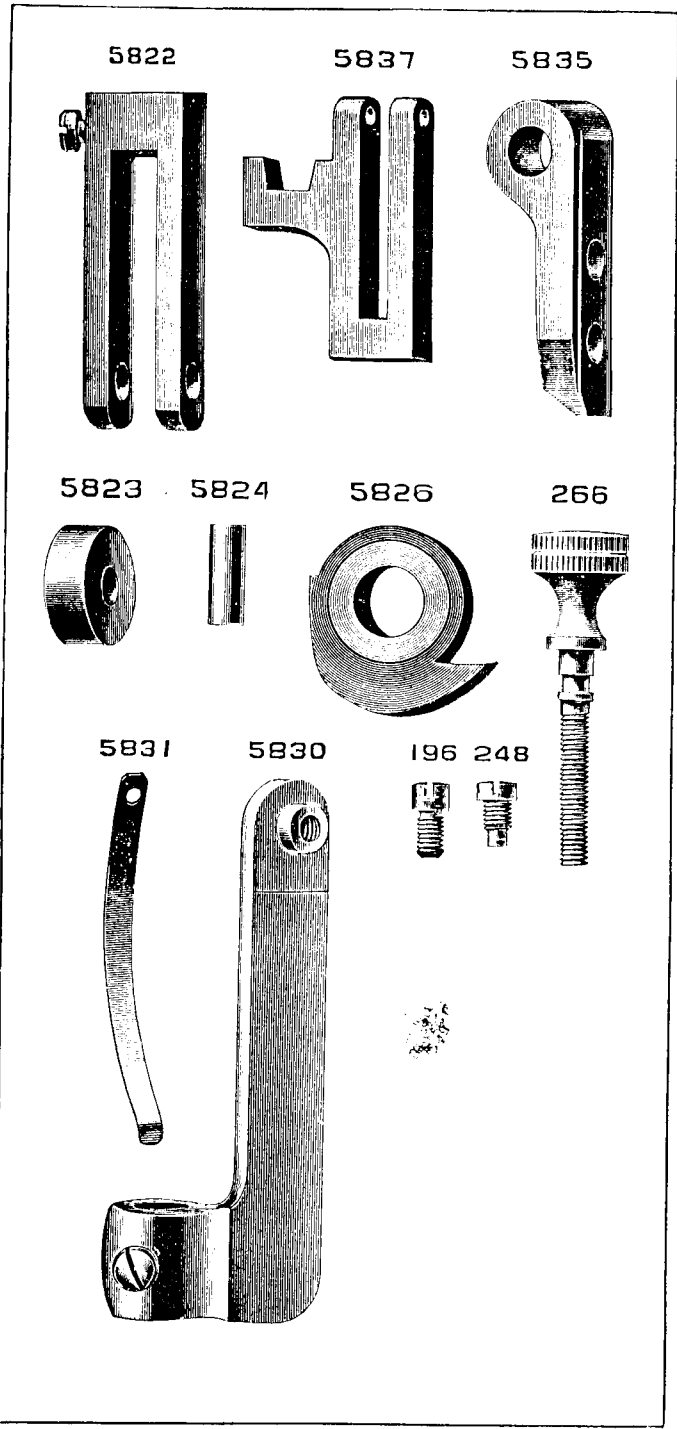
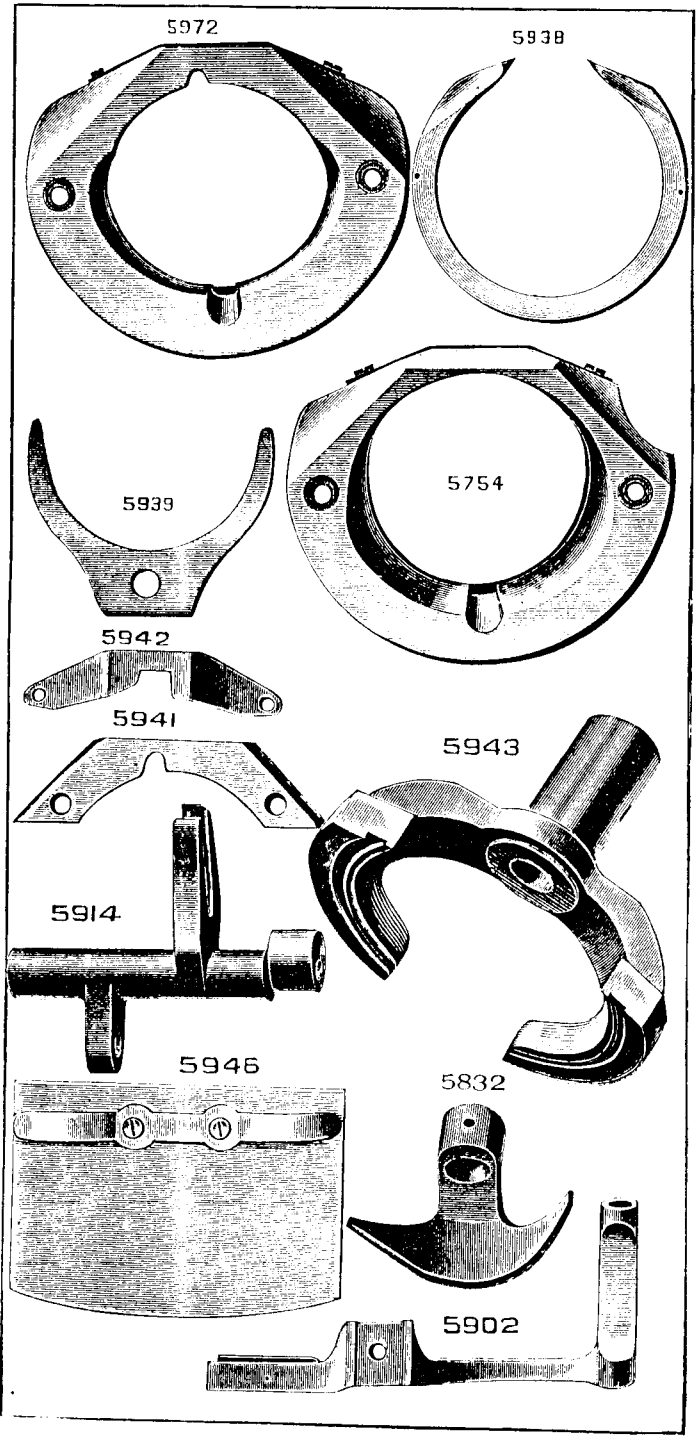


PLATE 677—ONE-HALF SIZE



From the library of: Diamond Needle Corp

PLATE 678—ONE-HALF SIZE

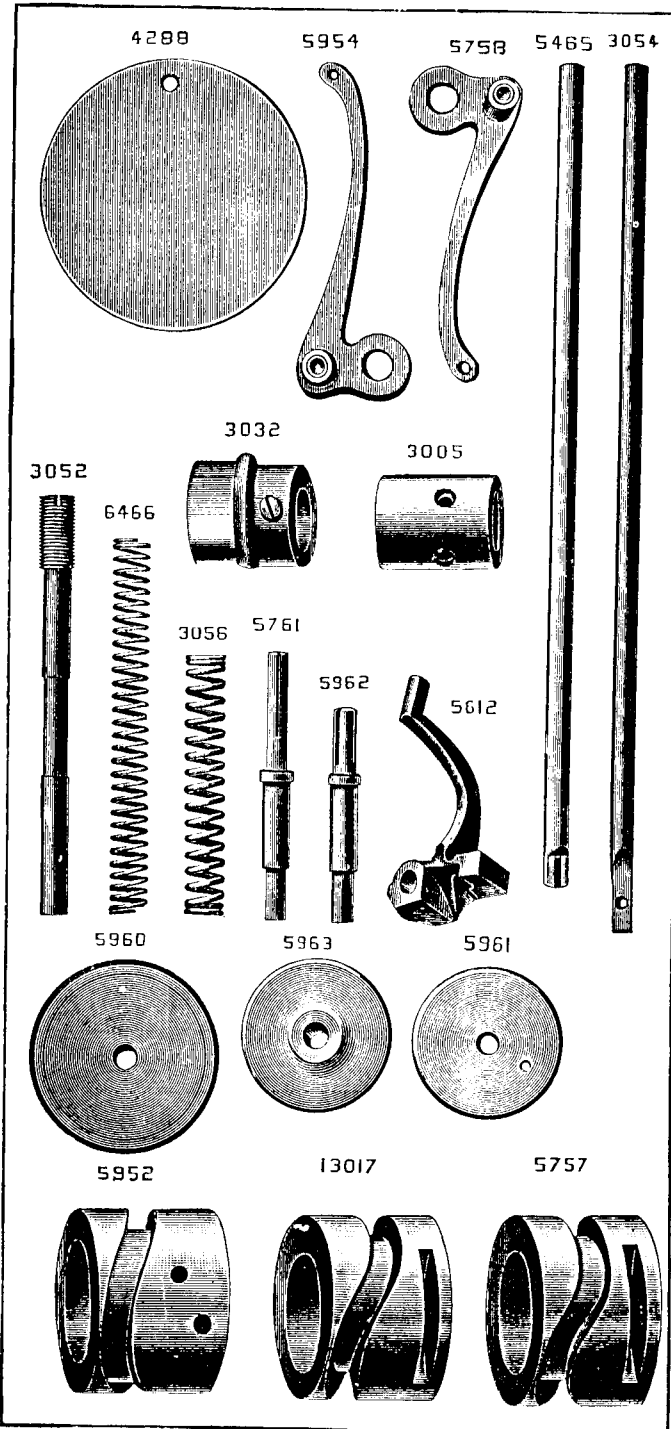


PLATE 679—ONE-HALF SIZE

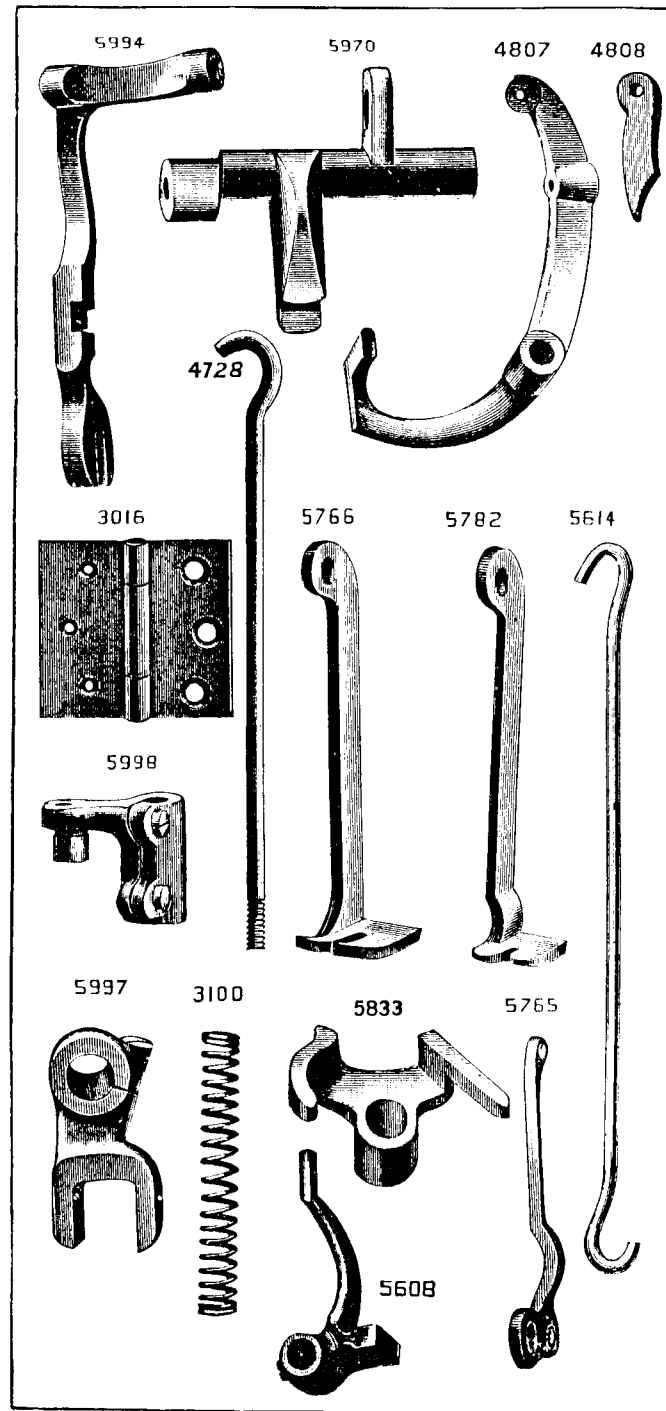


PLATE 680—ONE-HALF SIZE

8166 2058 4264 3126 5958 5959

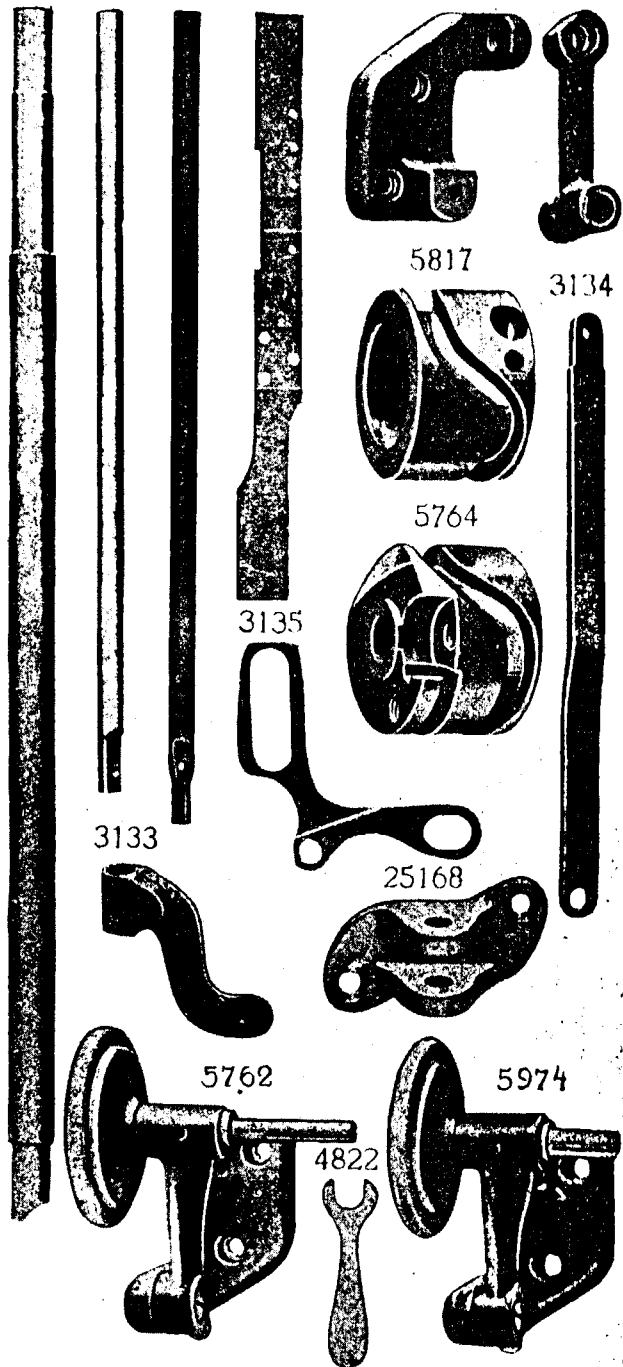


PLATE 681—FULL SIZE

5458 3045 5967 2062

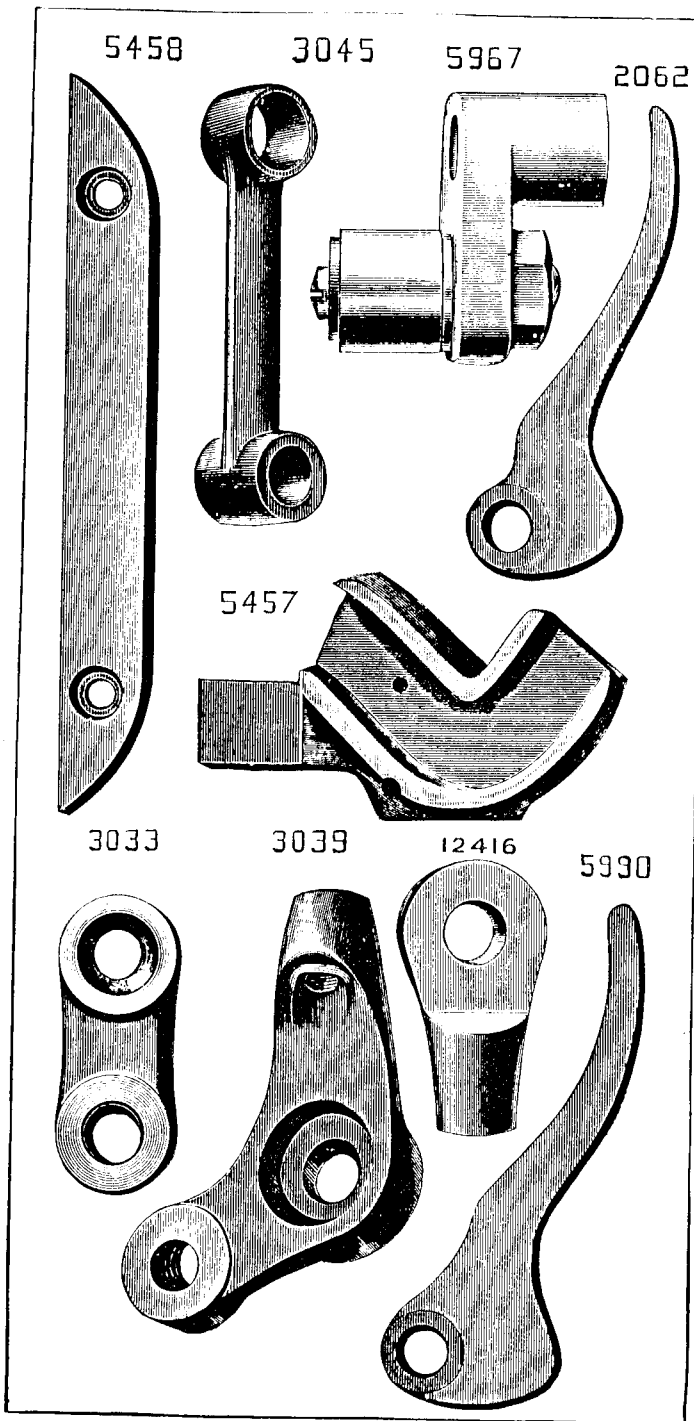


PLATE 682—FULL SIZE

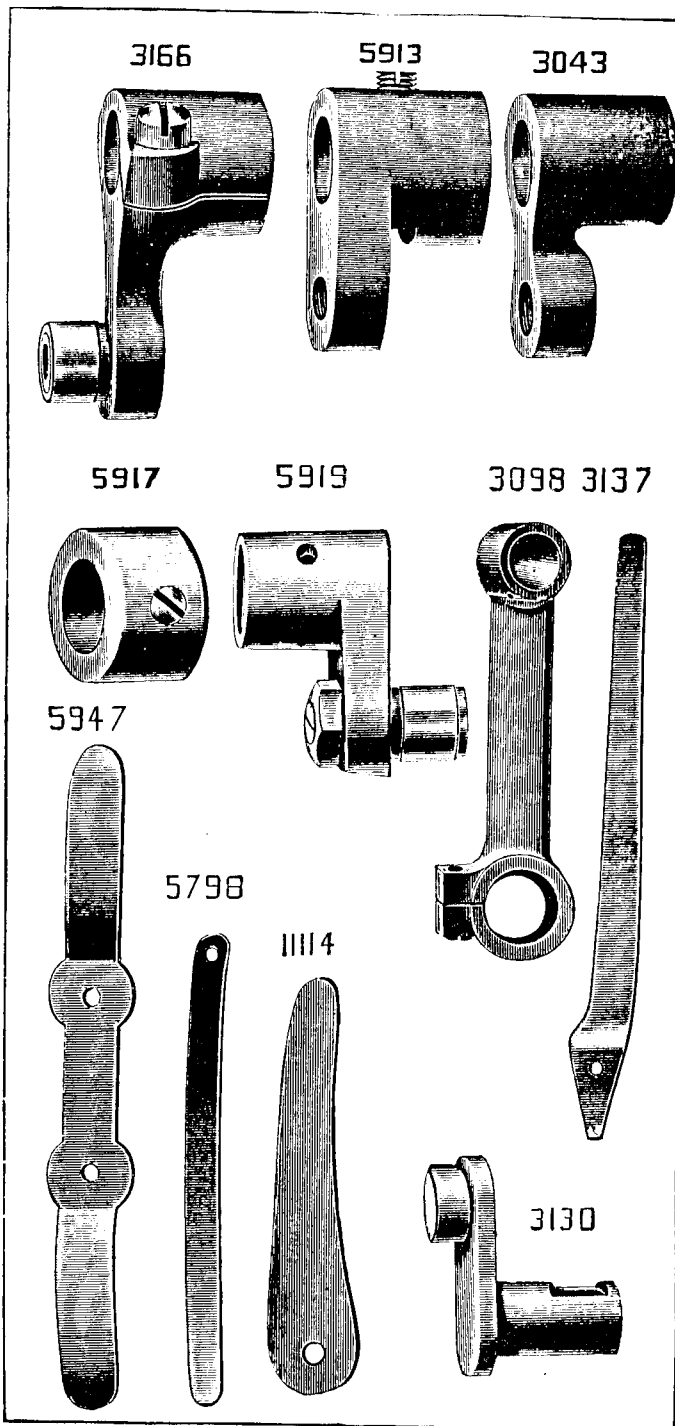


PLATE 683—FULL SIZE

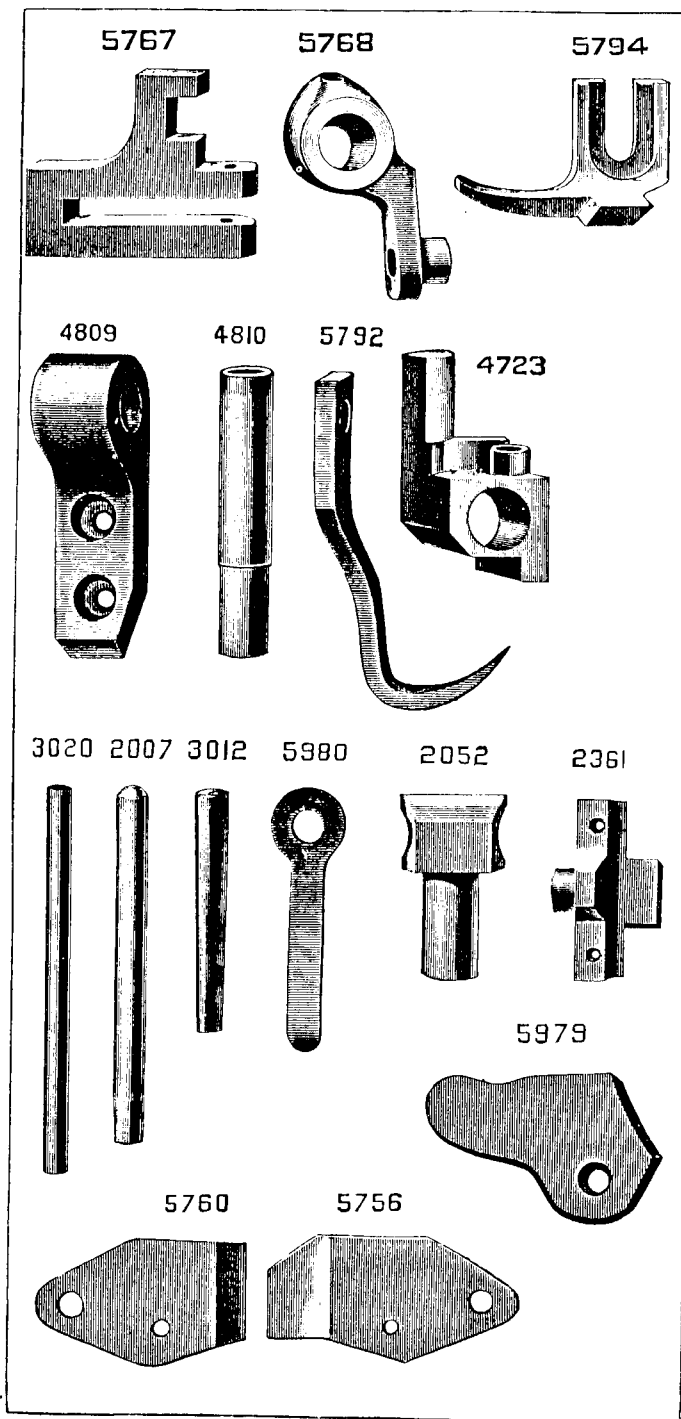


PLATE 684—FULL SIZE

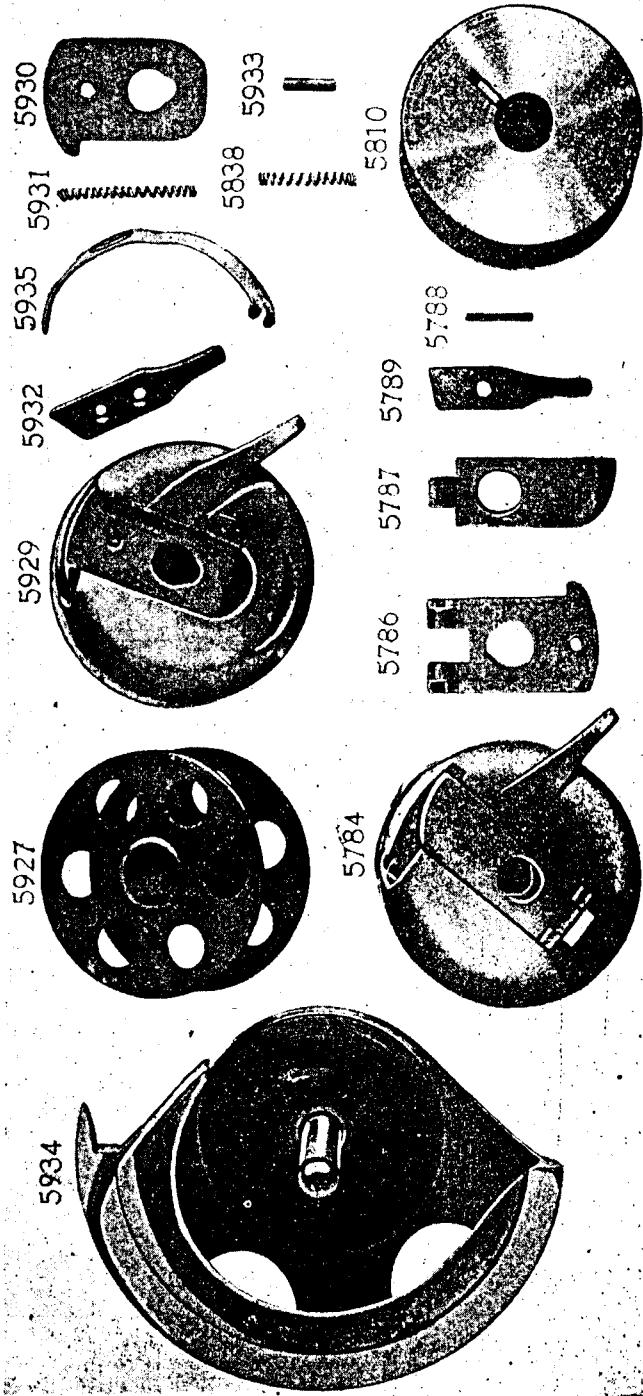


PLATE 685—FULL SIZE

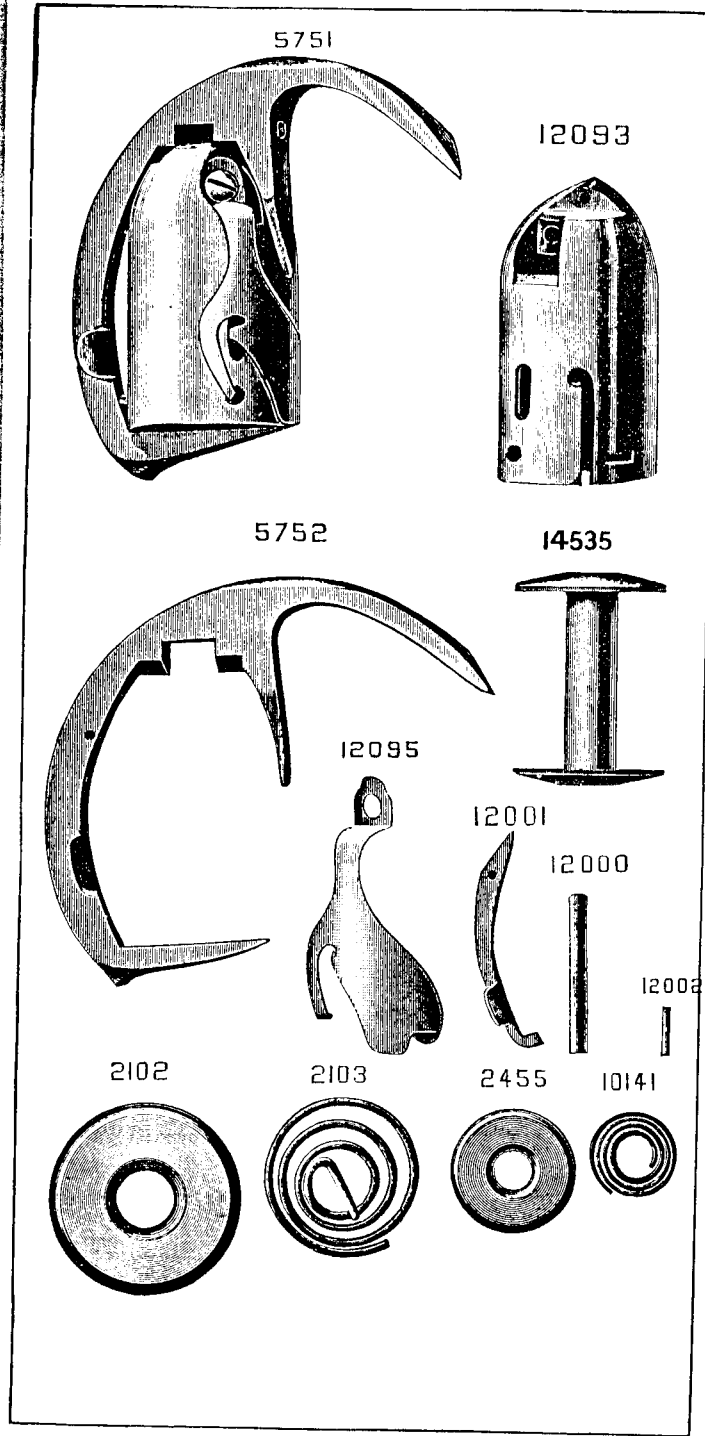


PLATE 686—FULL SIZE

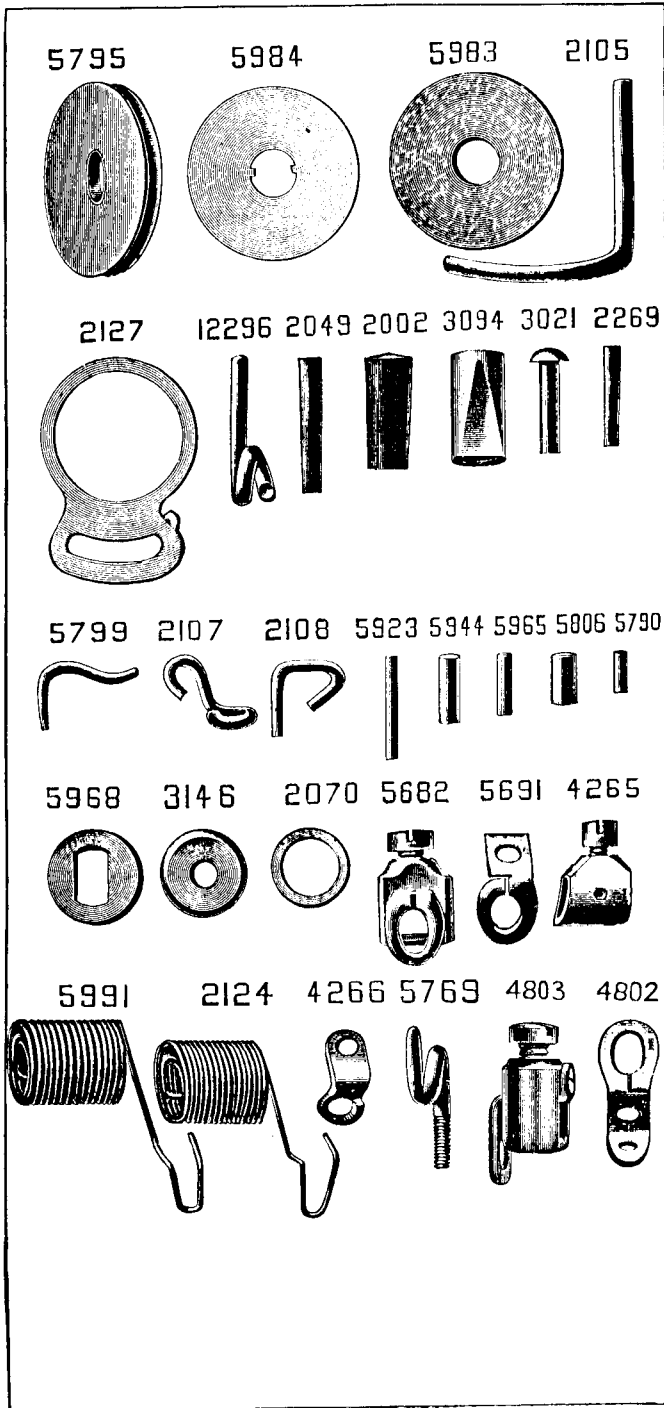


PLATE 687—FULL SIZE

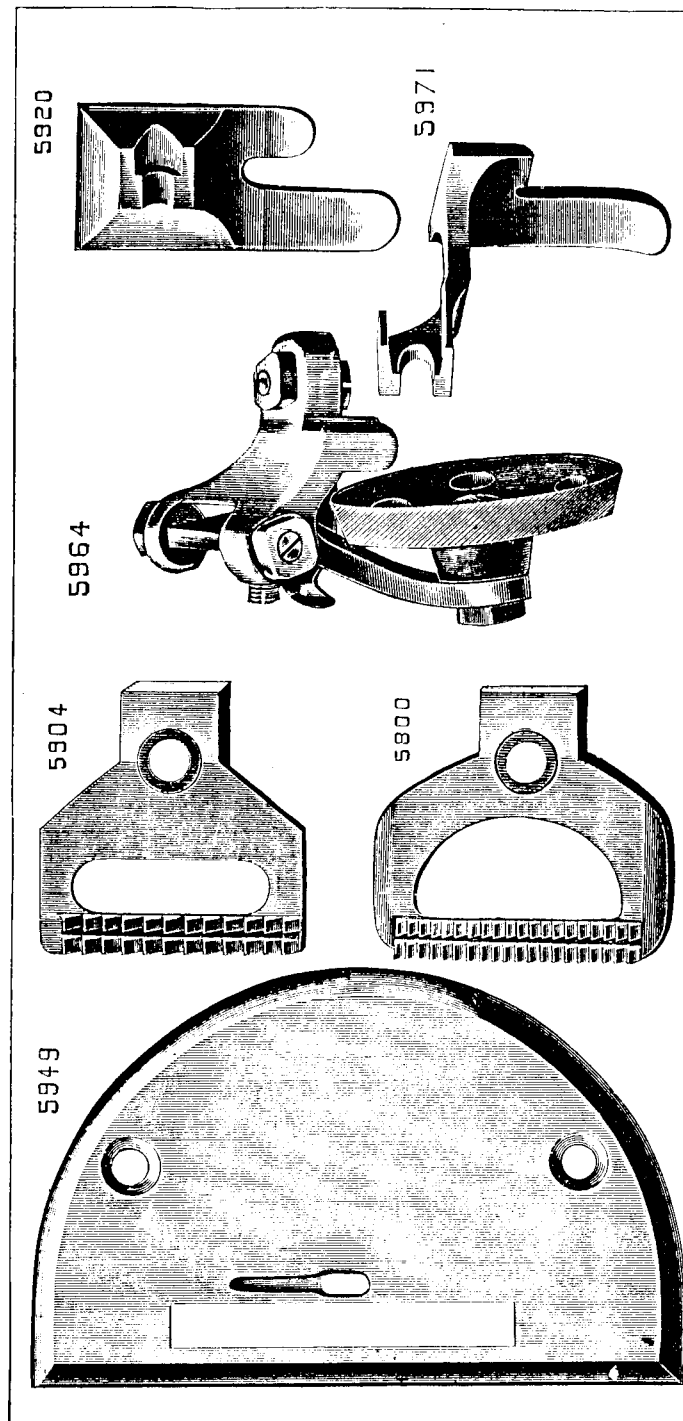


PLATE 688—FULL SIZE

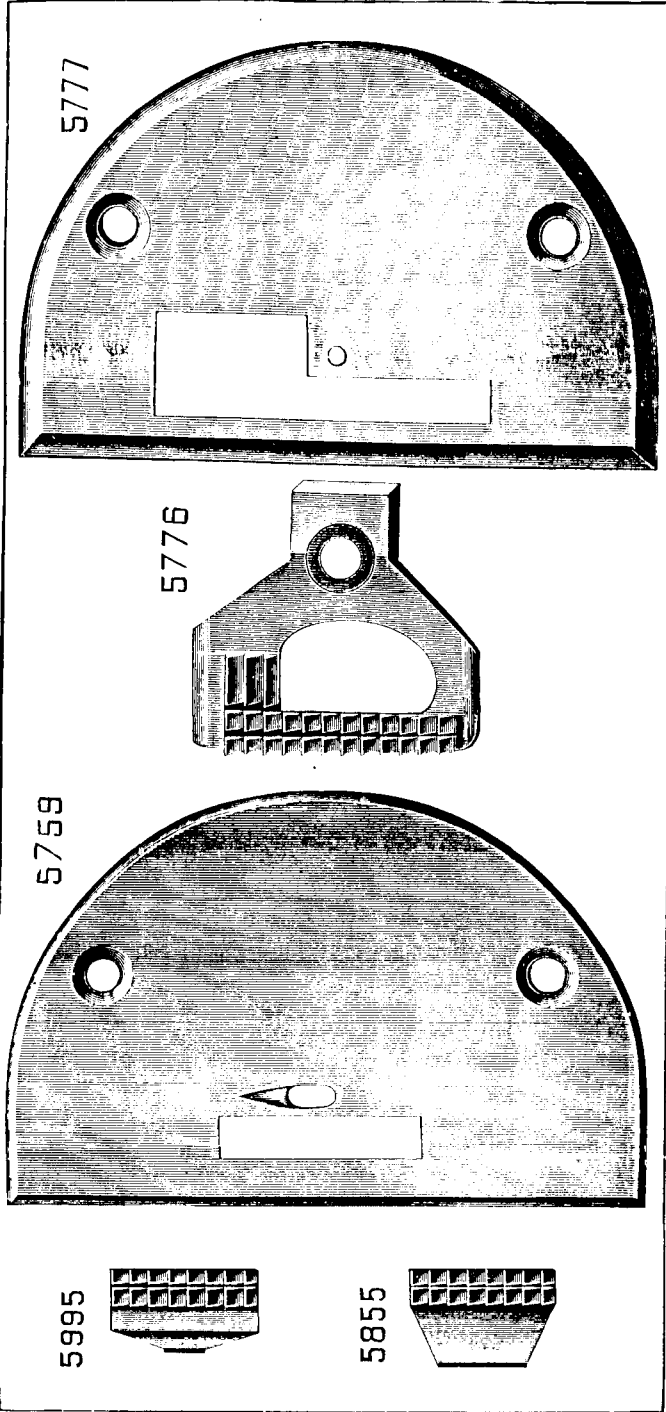


PLATE 689—FULL SIZE

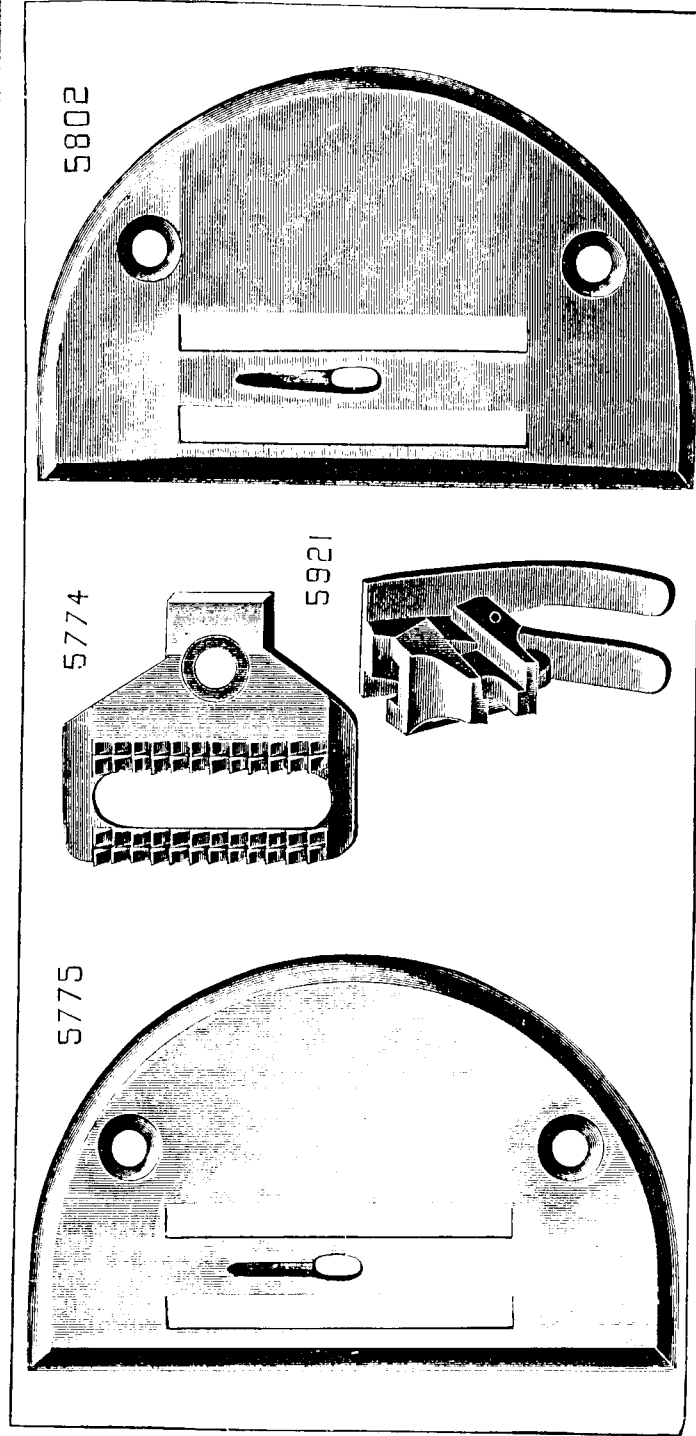
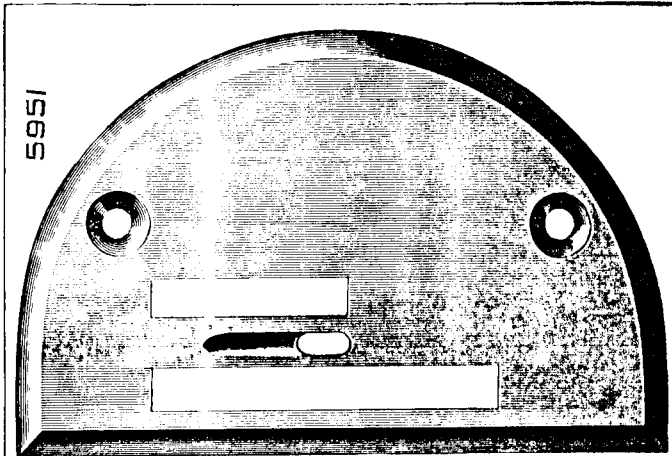
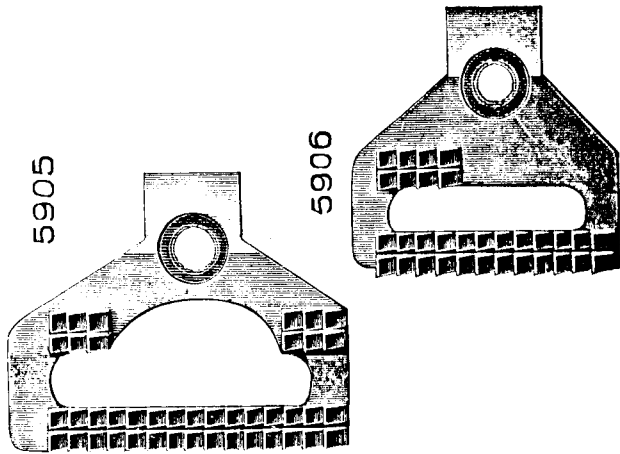


PLATE 690—FULL SIZE

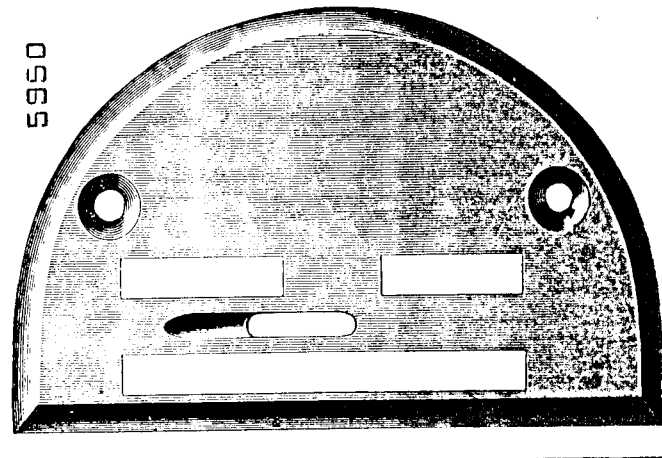


5951



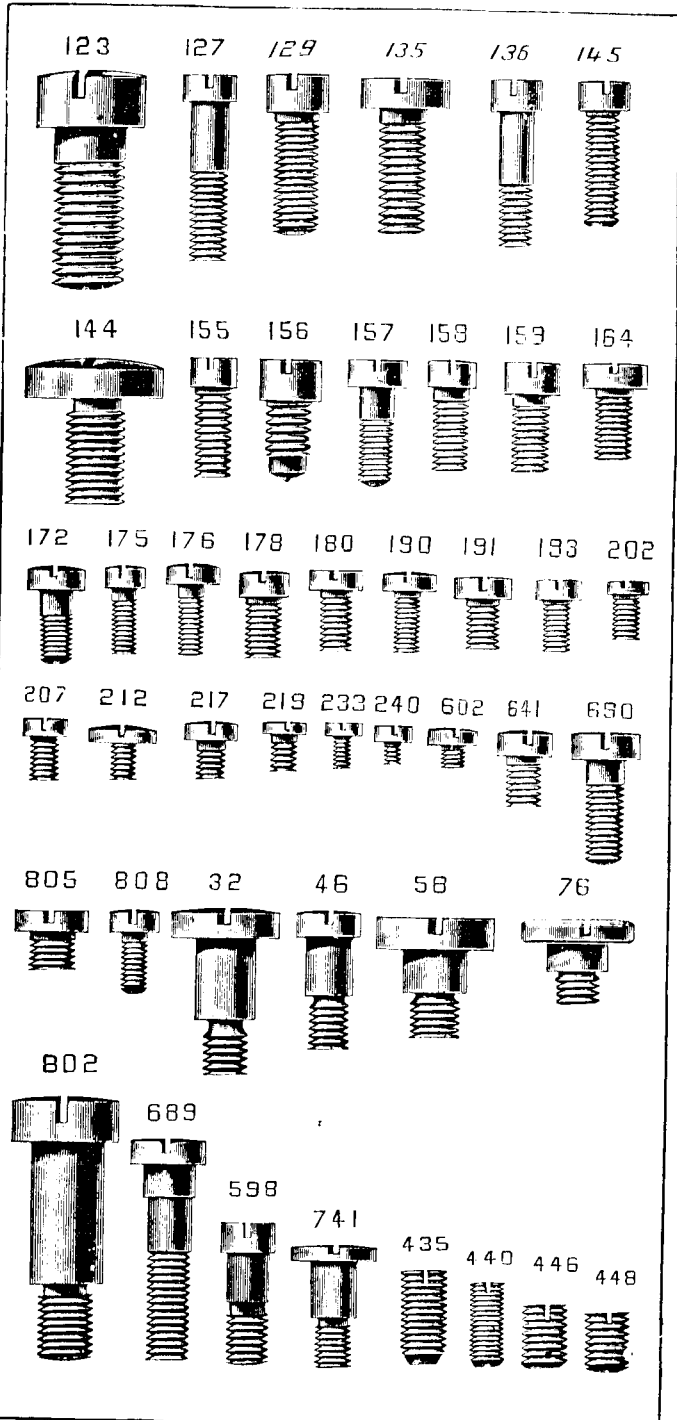
5905

5906



5950

PLATE 691—FULL SIZE



123

127

129

135

136

145

144

155

156

157

158

159

164

172

175

176

178

180

190

191

193

202

207

212

217

219

233

240

602

641

690

805

808

32

46

58

76

802

689

598

741

435

440

446

448

PLATE 692—FULL SIZE

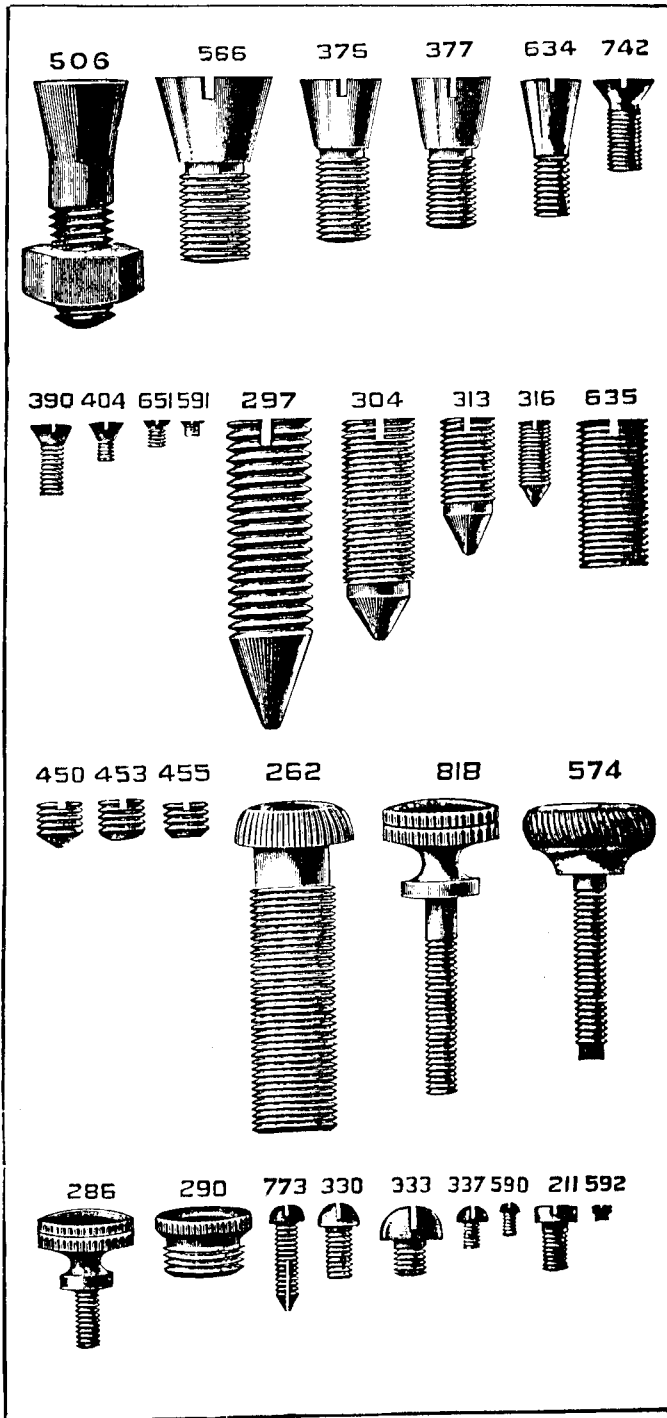


PLATE 693—FULL SIZE

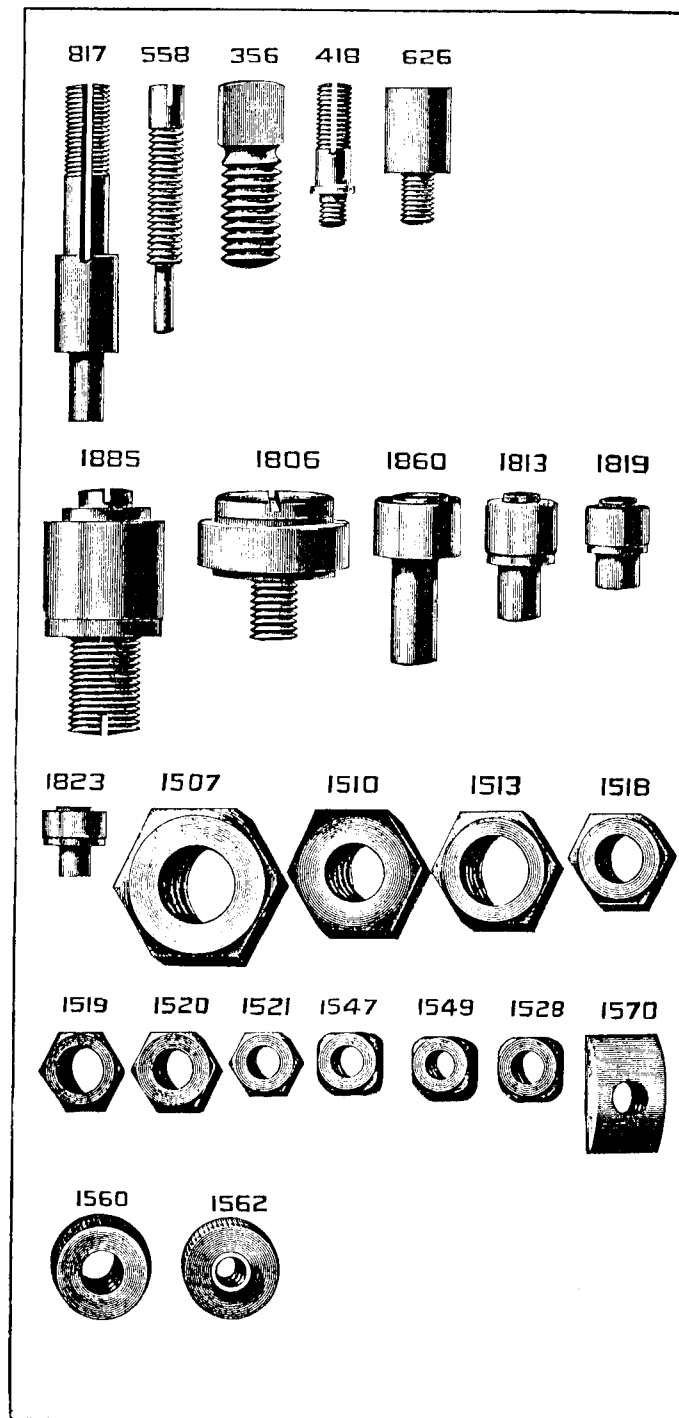


PLATE 694—FULL SIZE

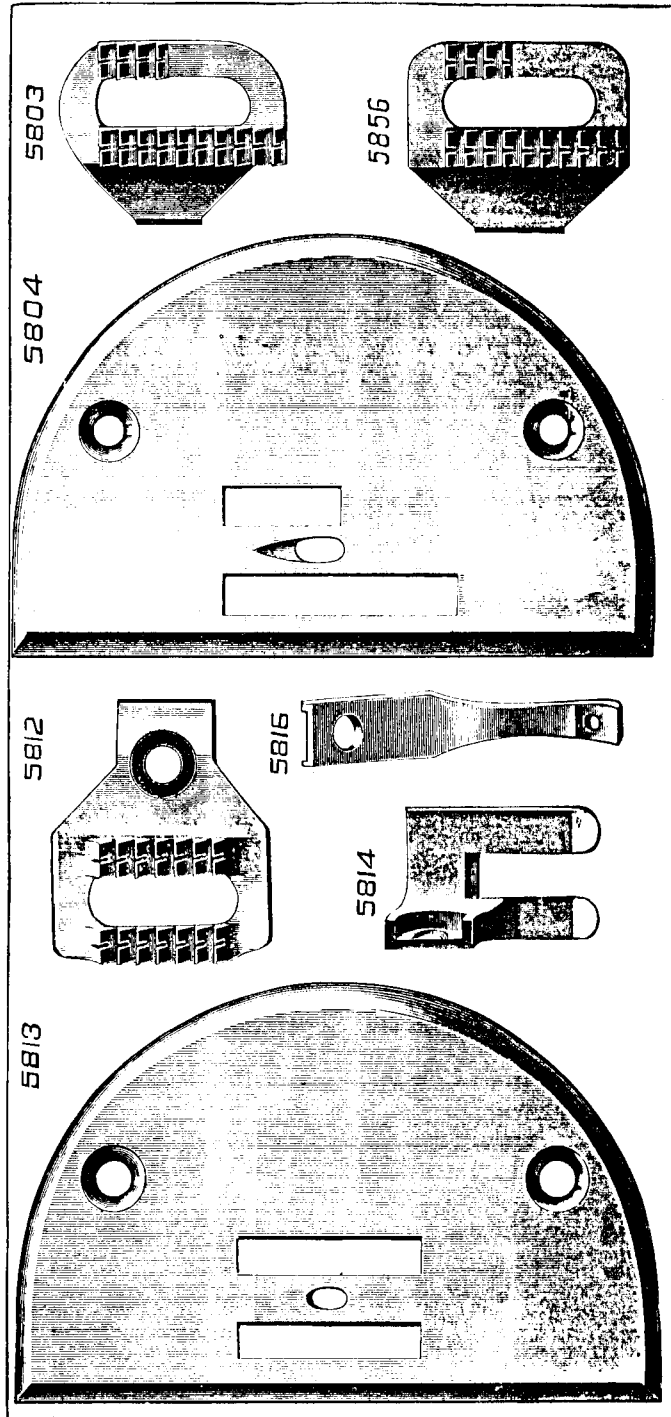


PLATE 695—FULL SIZE

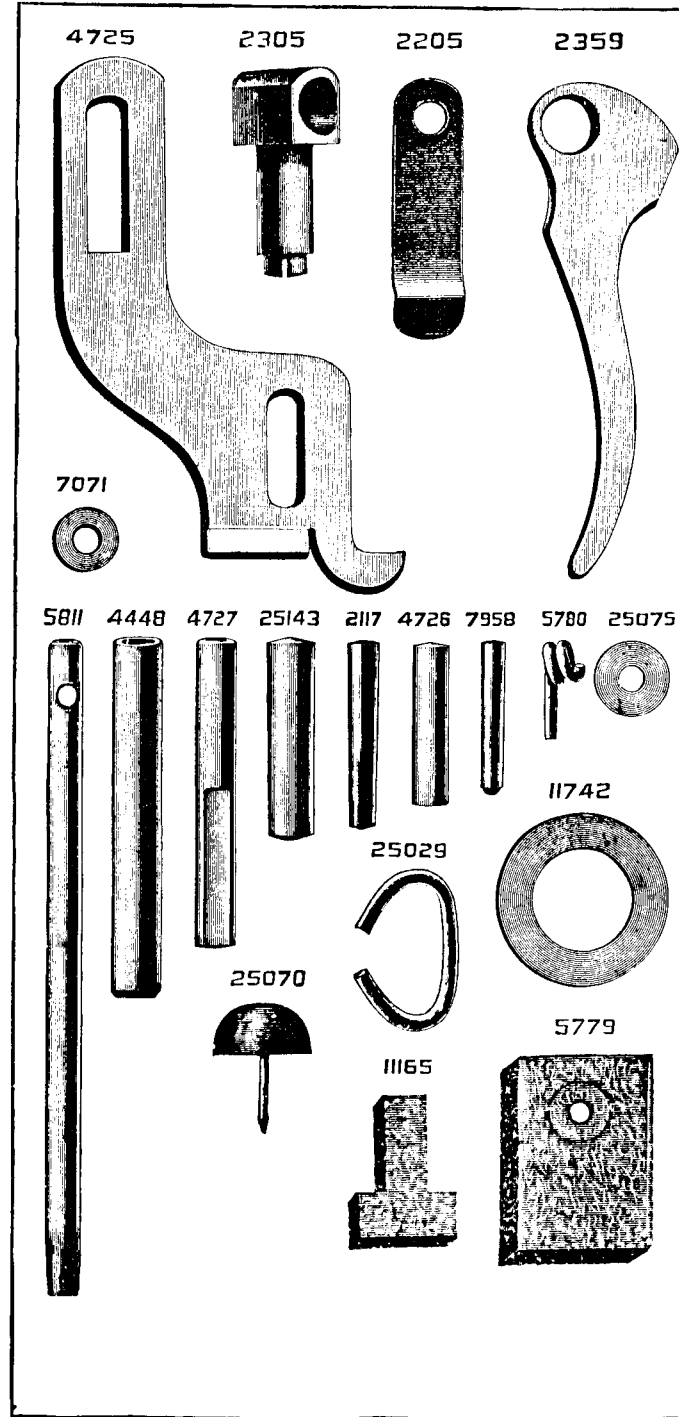


PLATE 696—ONE-FOURTH SIZE

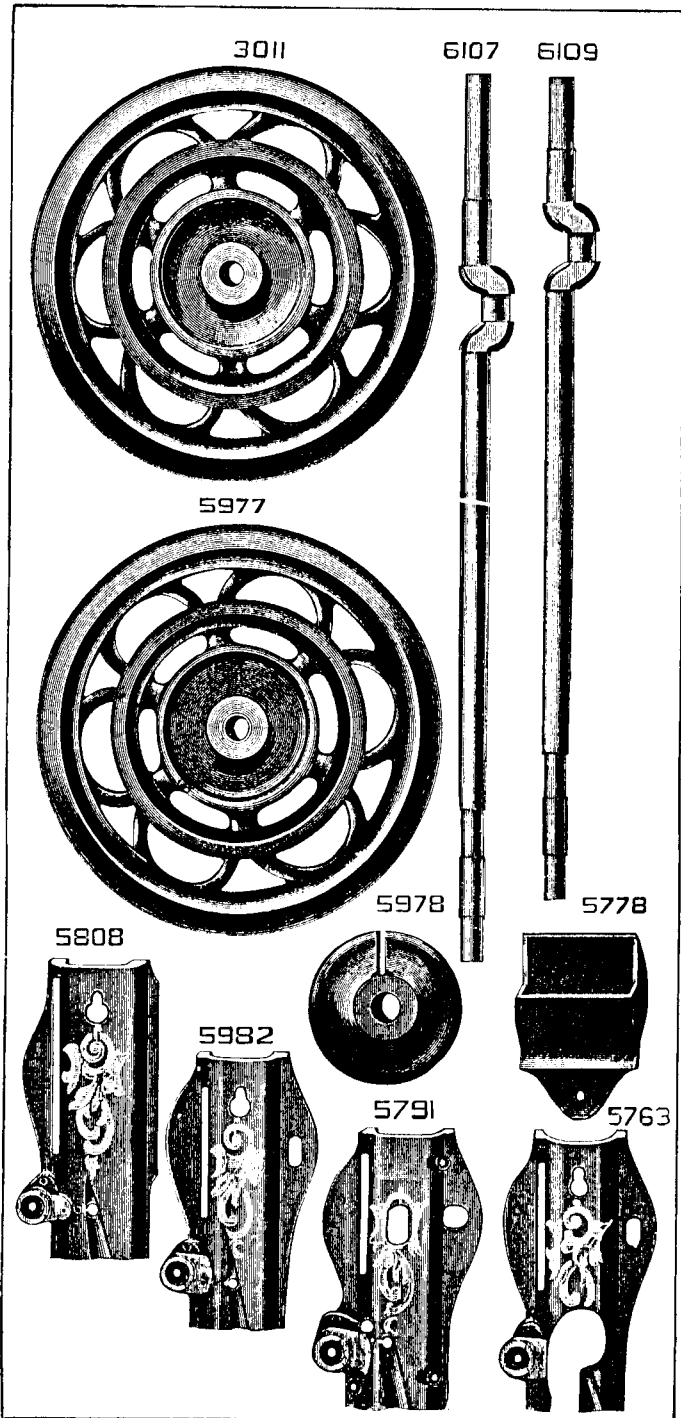


PLATE 1380—FULL SIZE

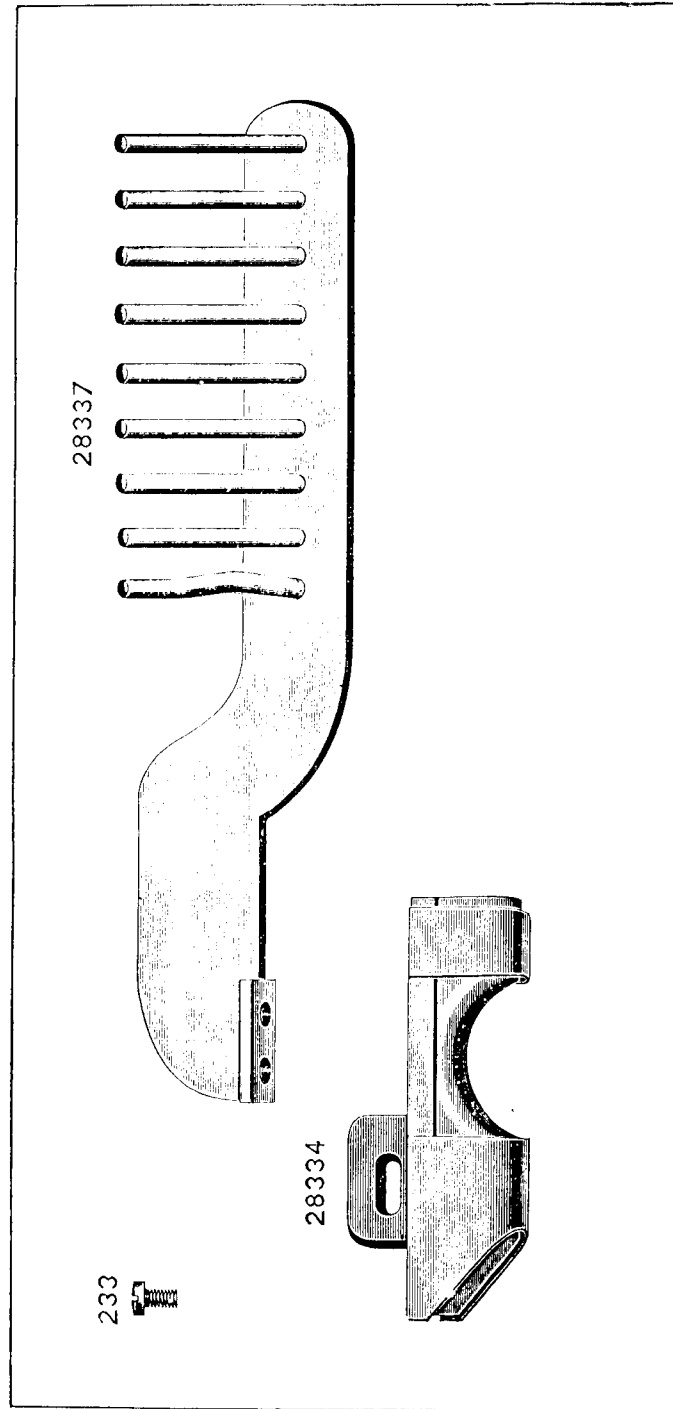


PLATE 3581—ONE-HALF SIZE

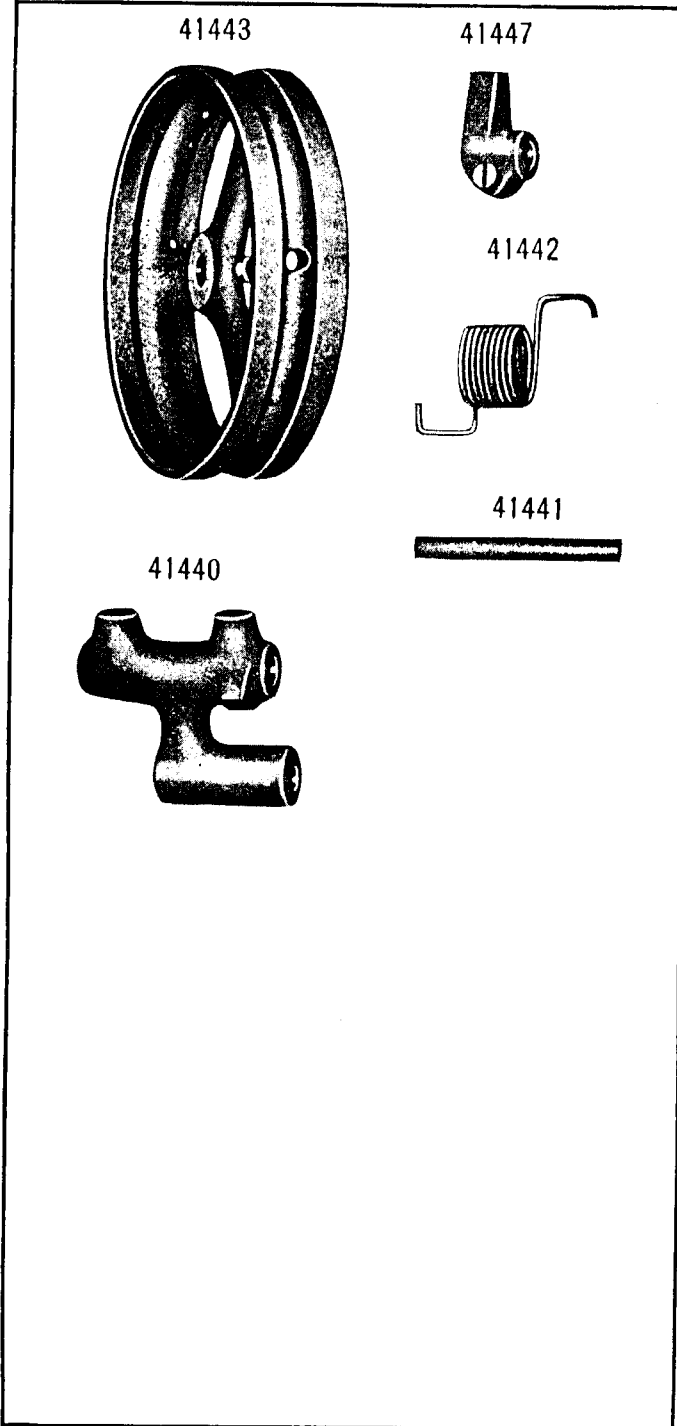


PLATE 3582—ONE-FOURTH SIZE

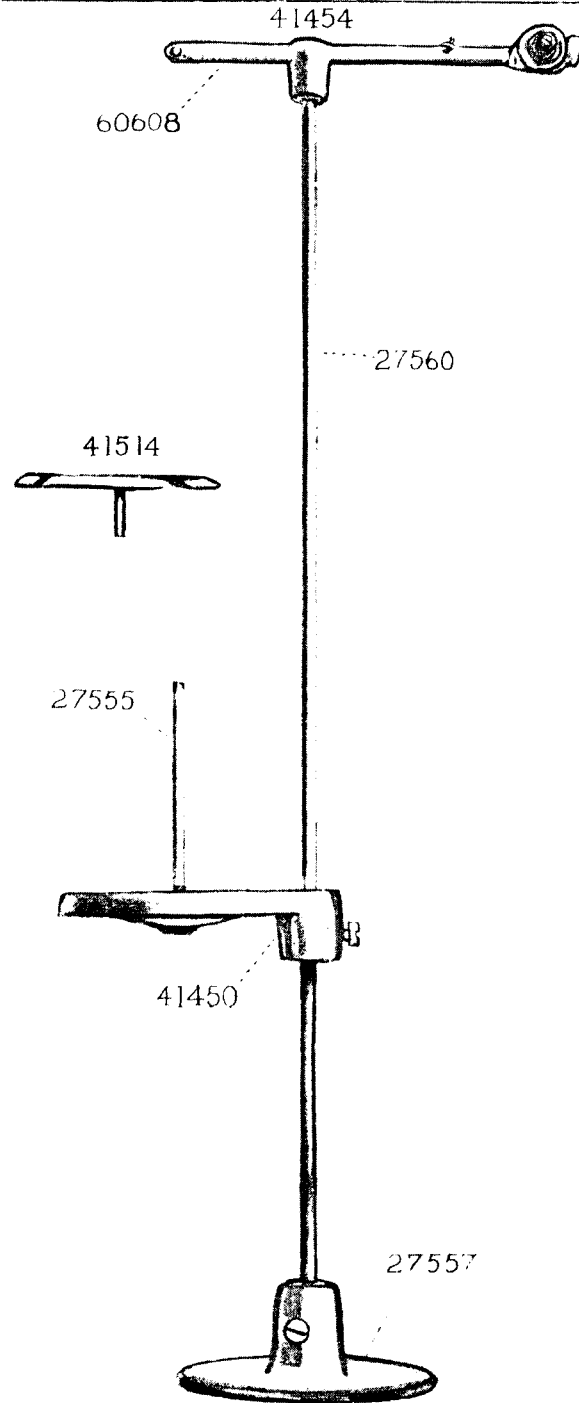


PLATE 3583—FULL SIZE

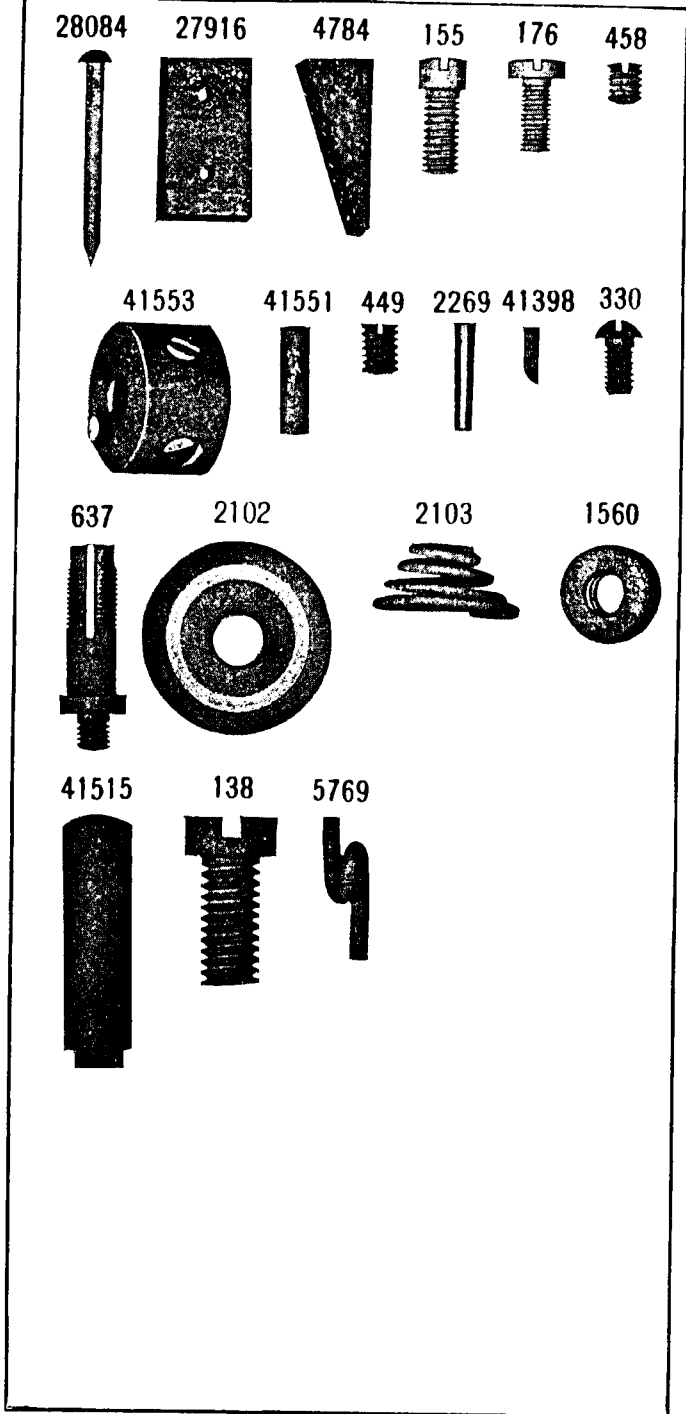
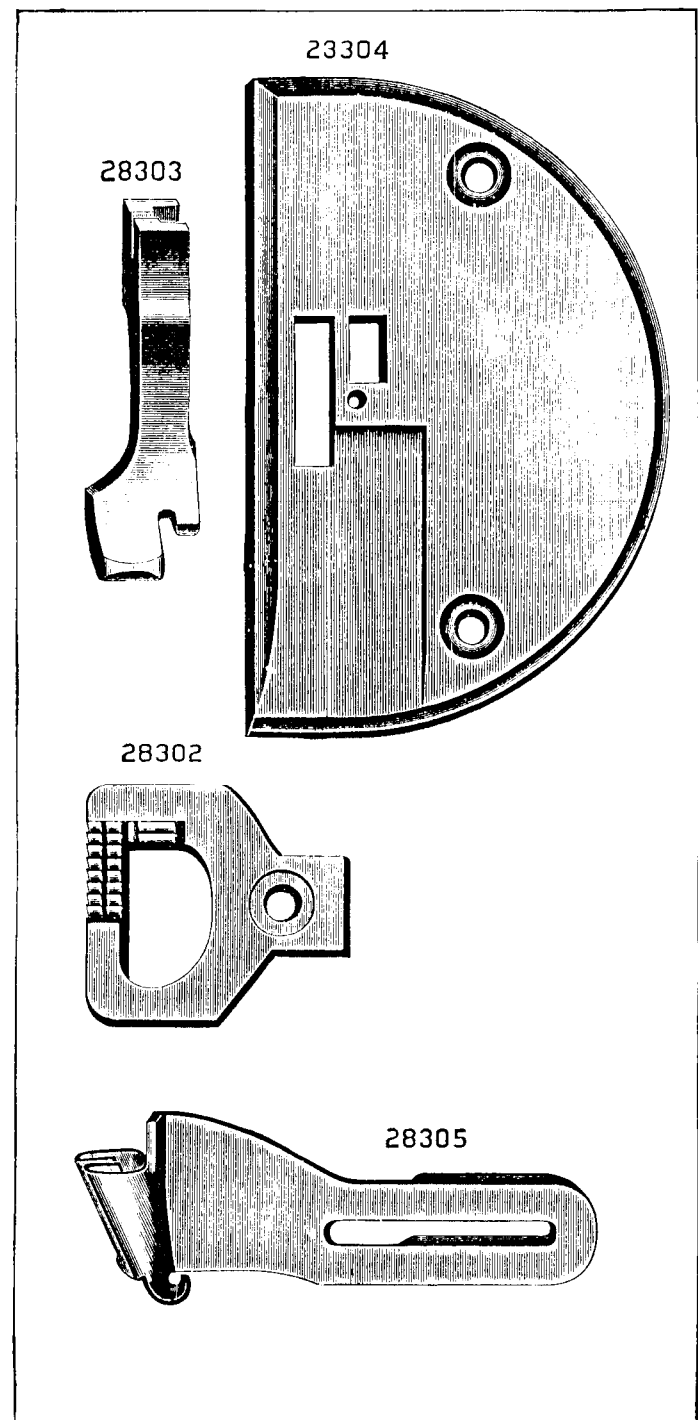


PLATE 3600—FULL SIZE



From the library of: Diamond Needle Corp

PLATE 3602—FULL SIZE

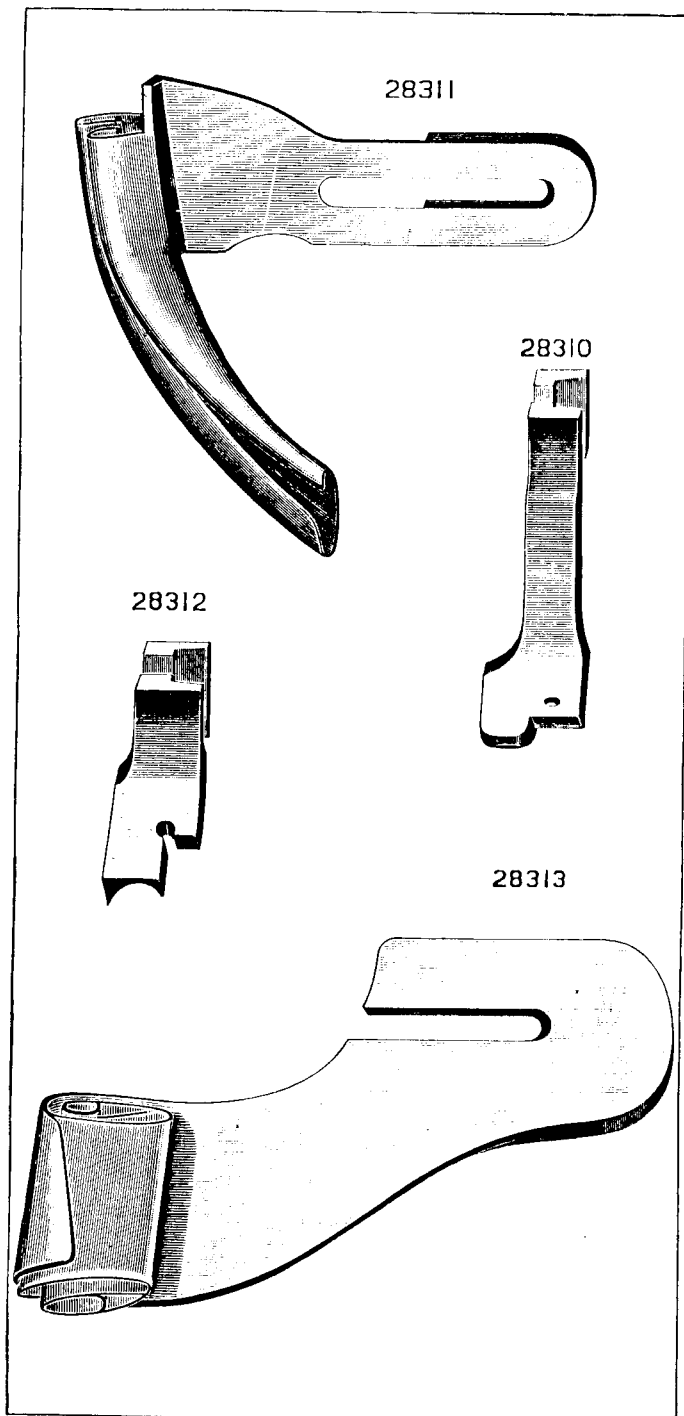


PLATE 3604—FULL SIZE

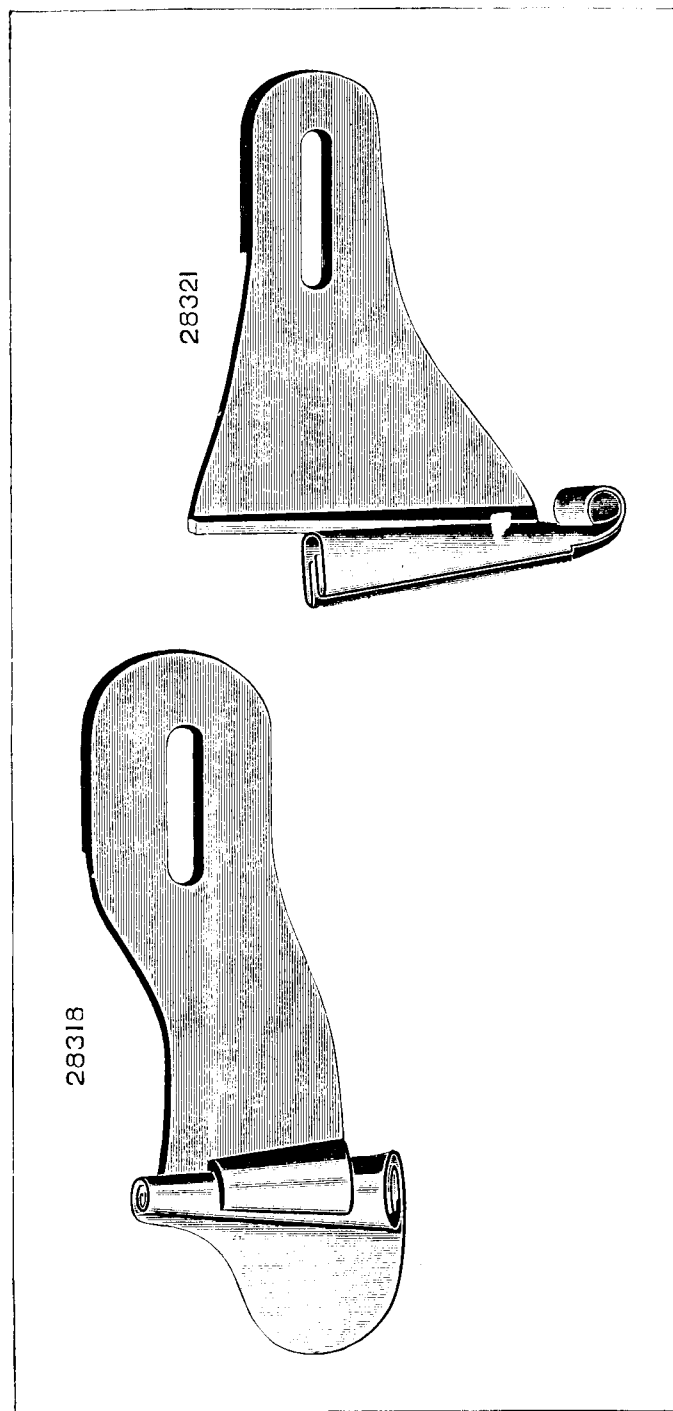


PLATE 3605—FULL SIZE

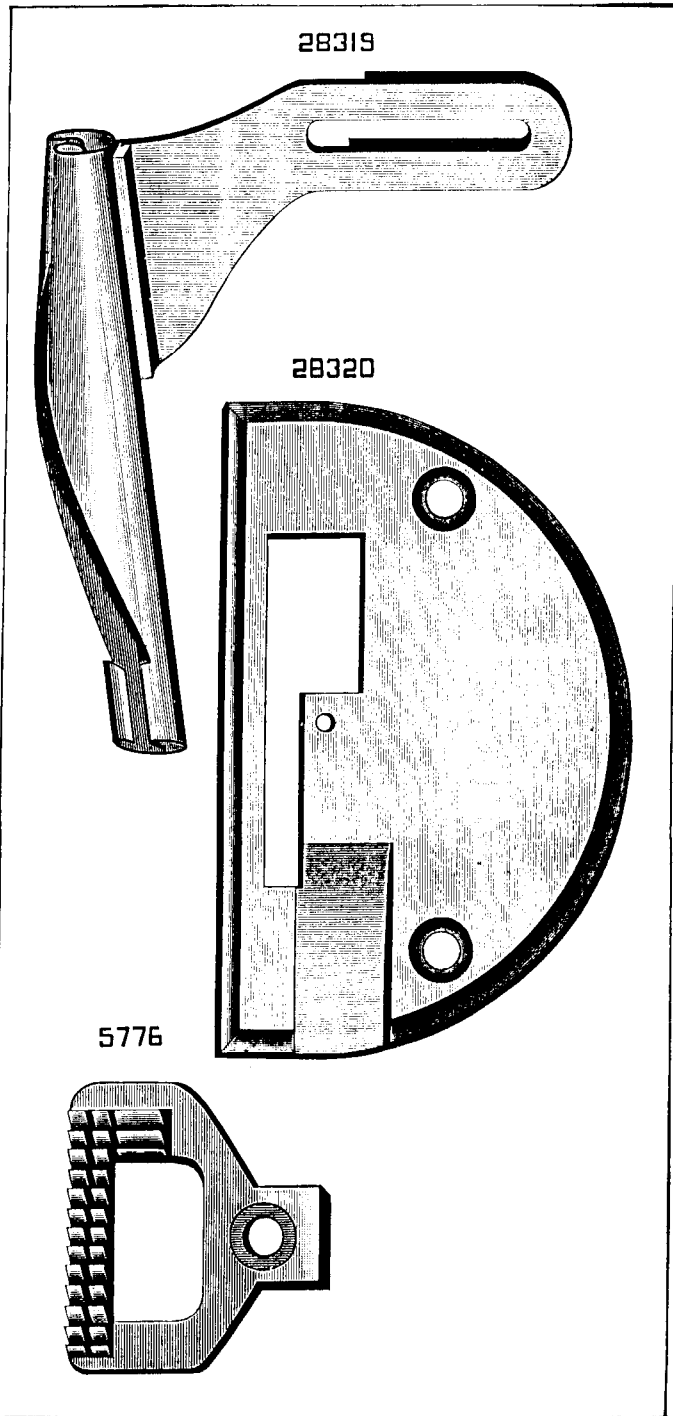


PLATE 3606—FULL SIZE

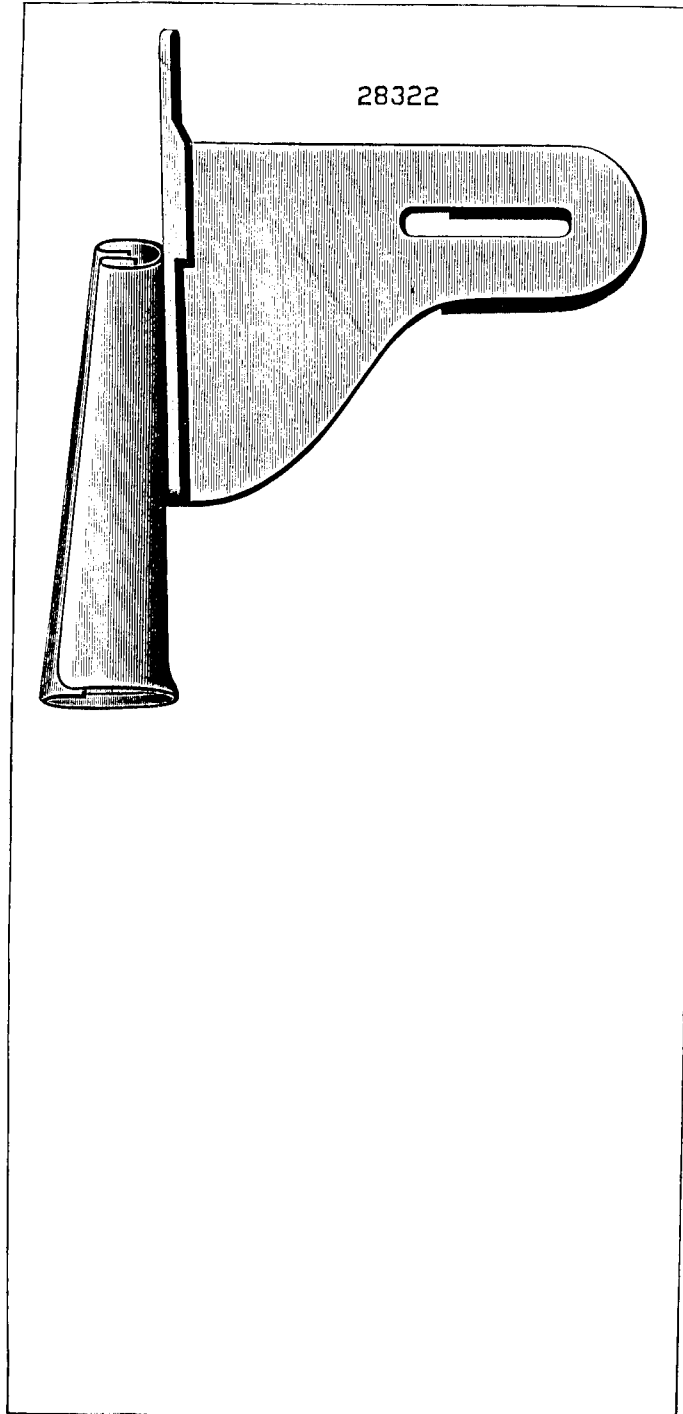
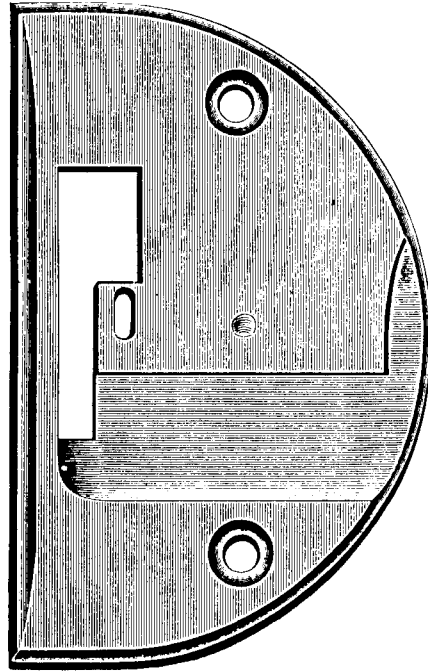


PLATE 3610—FULL SIZE

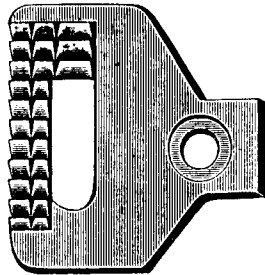
28338



28335



5888



28339

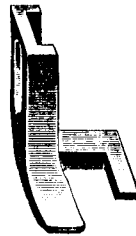
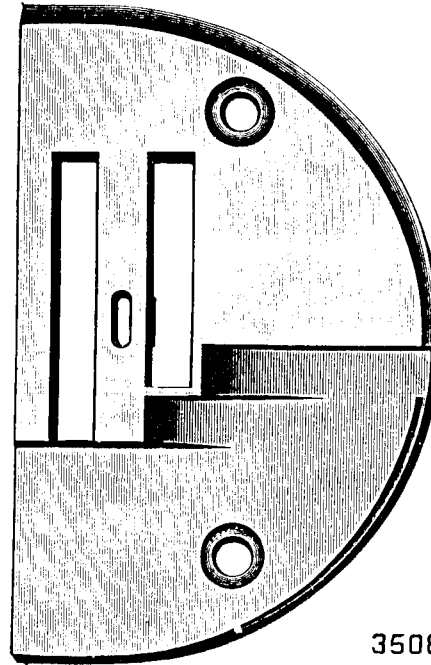
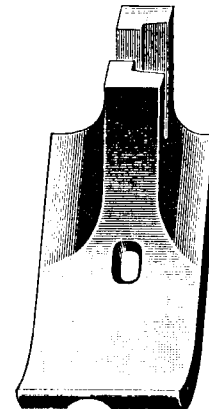


PLATE 3621—FULL SIZE

35088



35087



35086

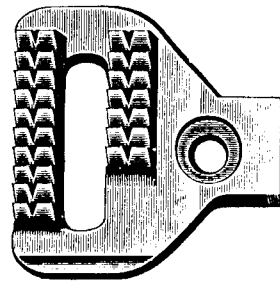


PLATE 3622 -FULL SIZE

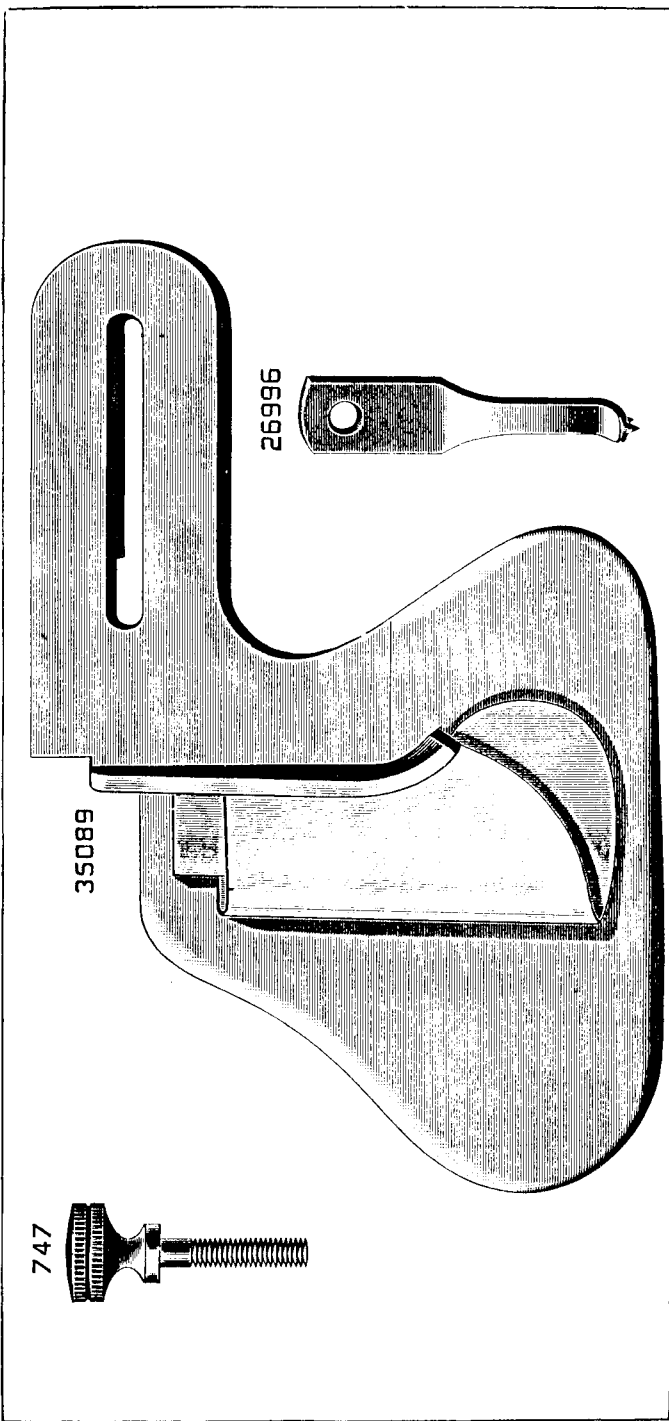


PLATE 3623—FULL SIZE

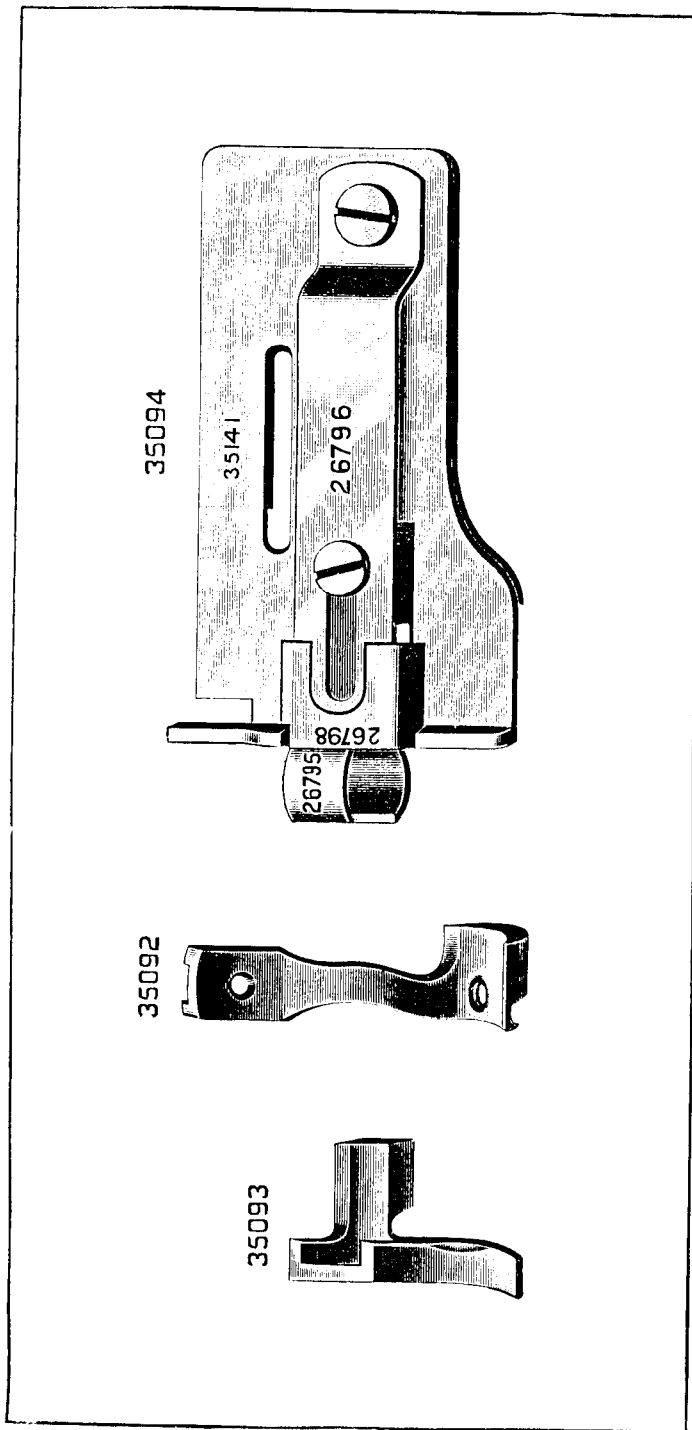
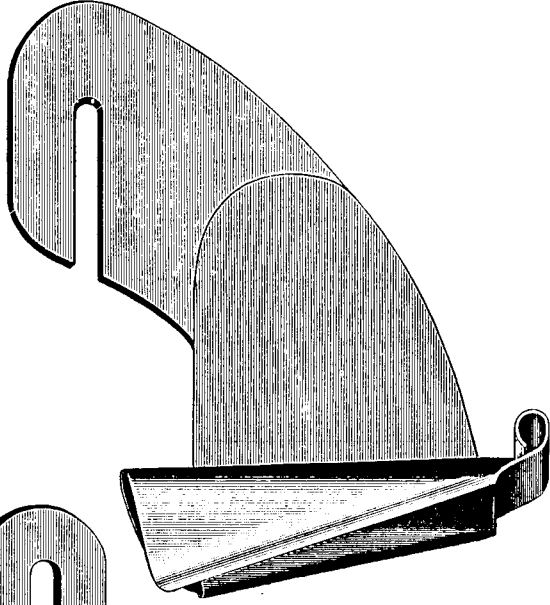
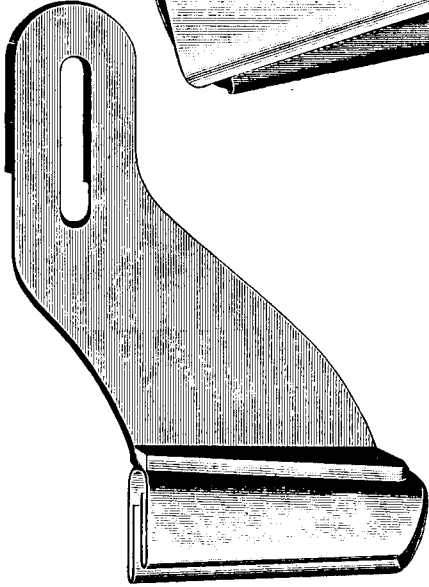


PLATE 3625—FULL SIZE

26999



26998



26997

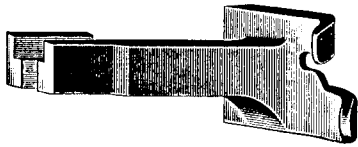


PLATE 3626—ONE-HALF SIZE

27000

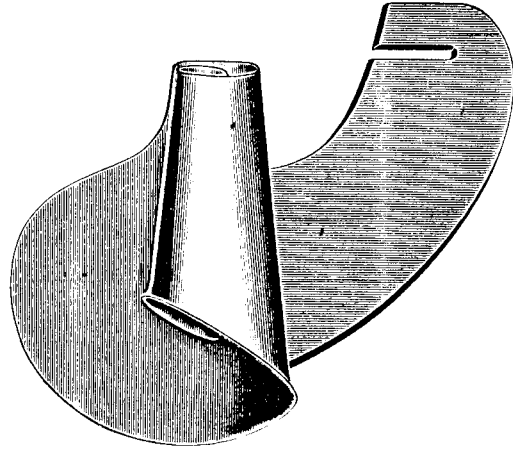


PLATE 3627—ONE-FOURTH SIZE

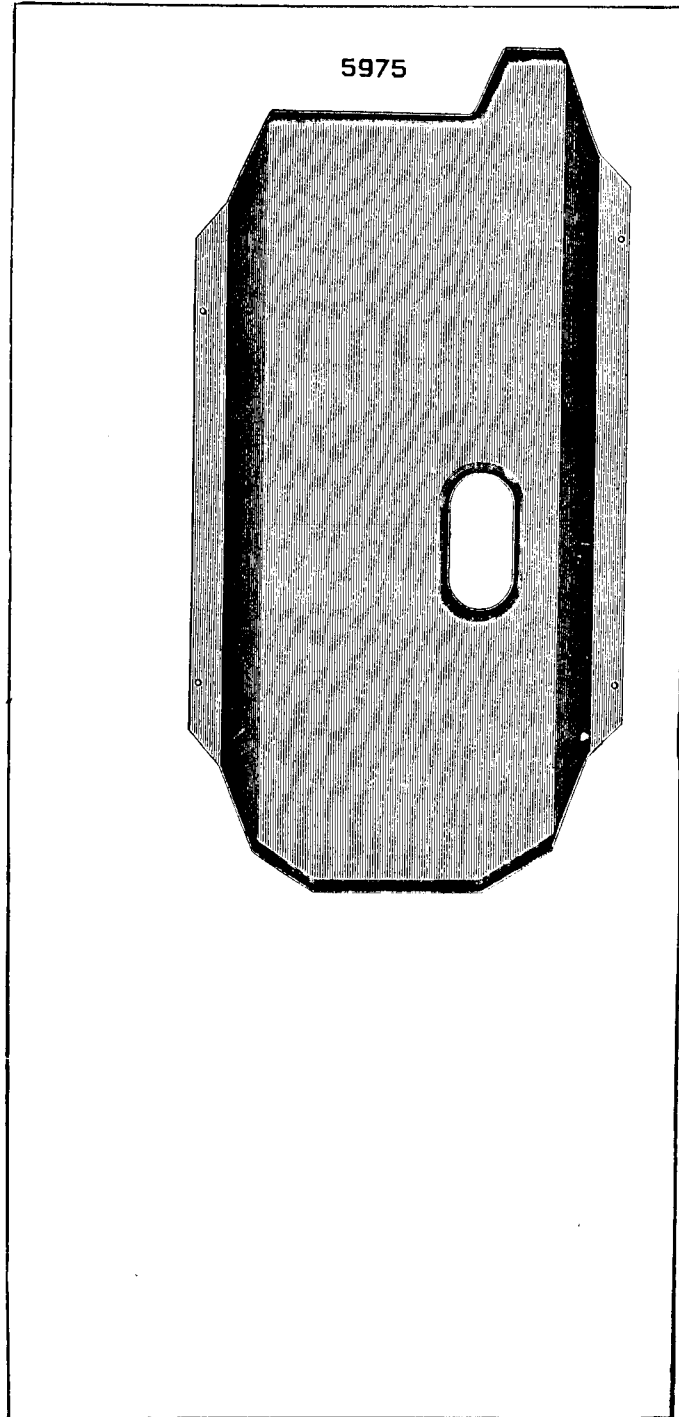


PLATE 3628—ONE-FOURTH SIZE

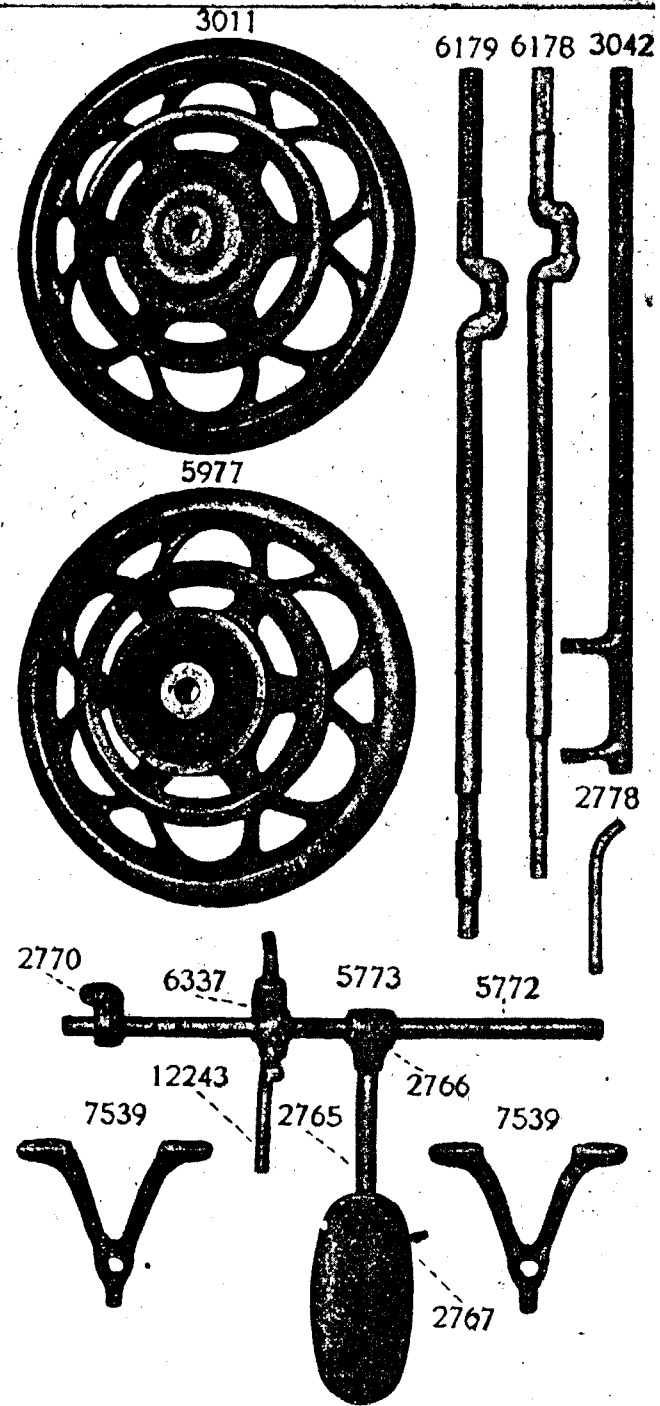


PLATE 3633—FULL SIZE

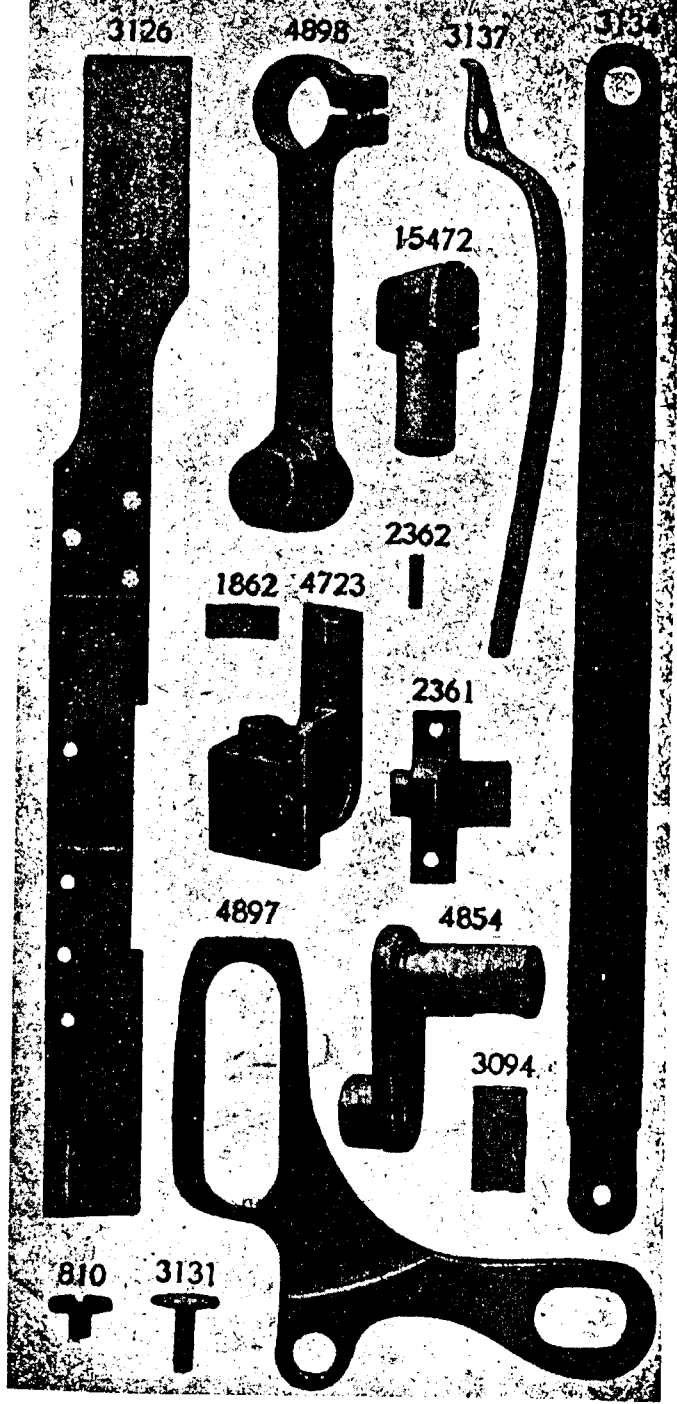
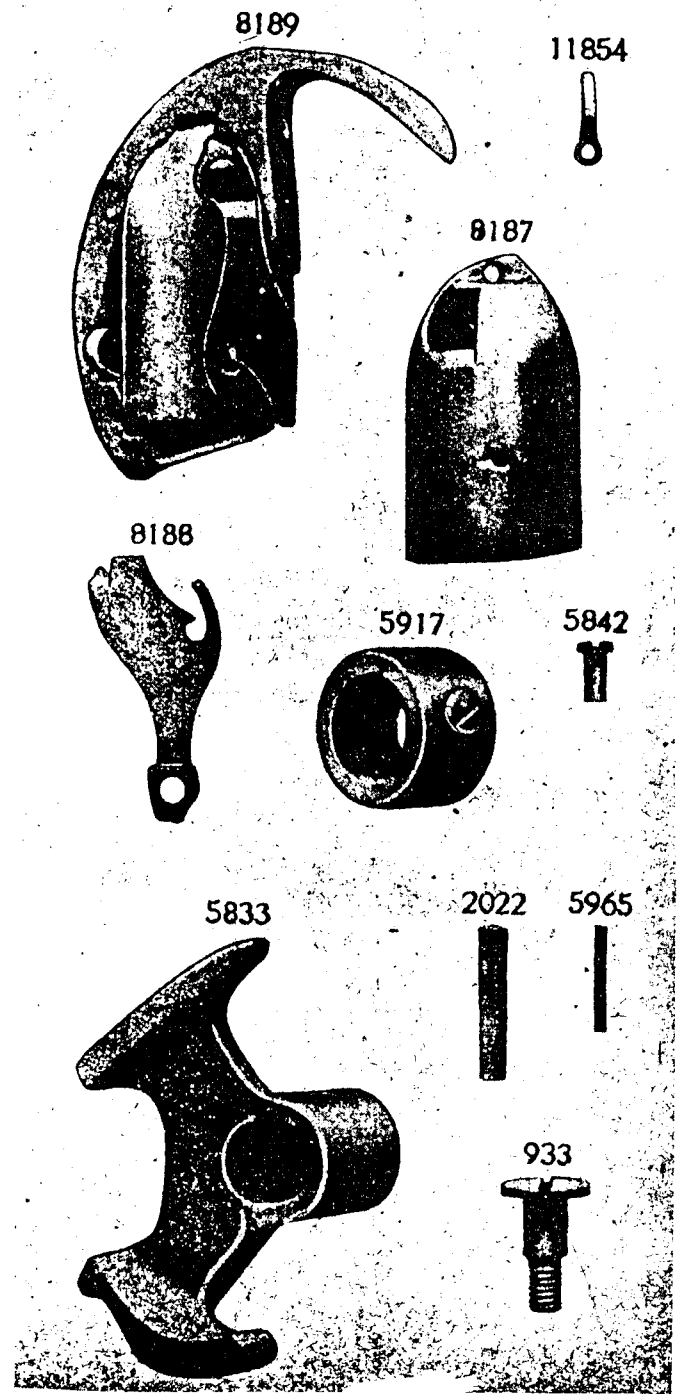


PLATE 3634—FULL SIZE



From the library of: Diamond Needle Corp

PLATE 3635—ONE-HALF SIZE

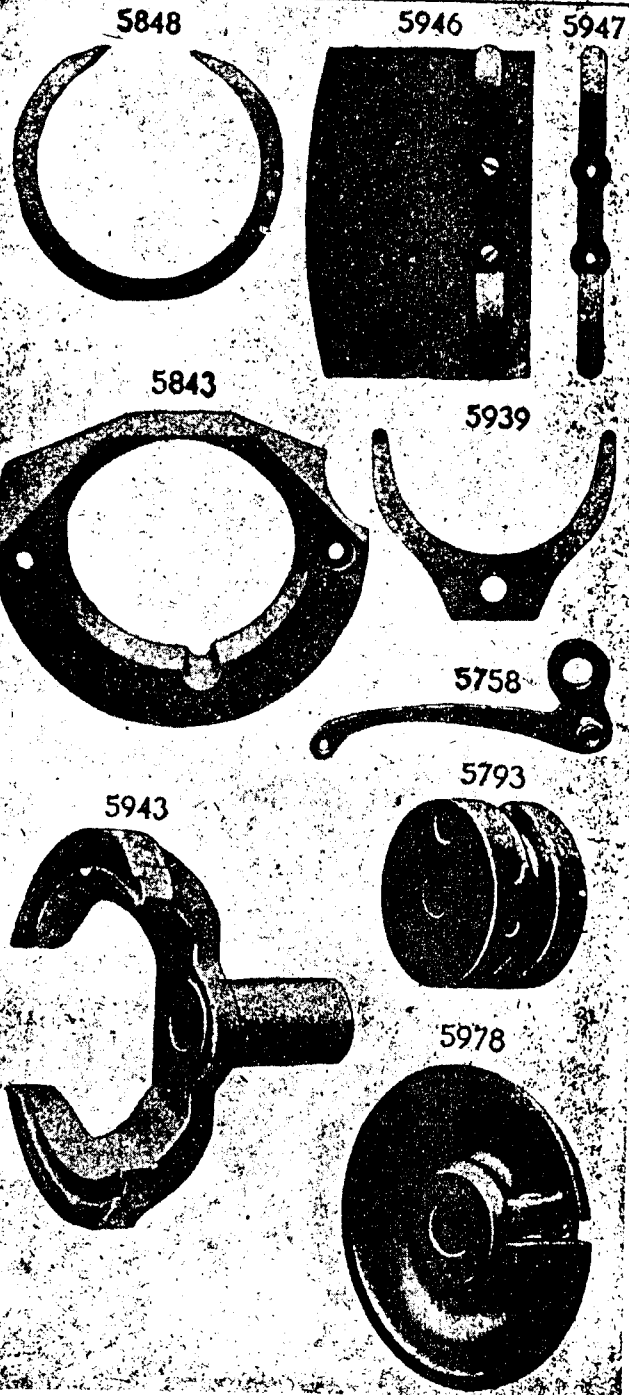
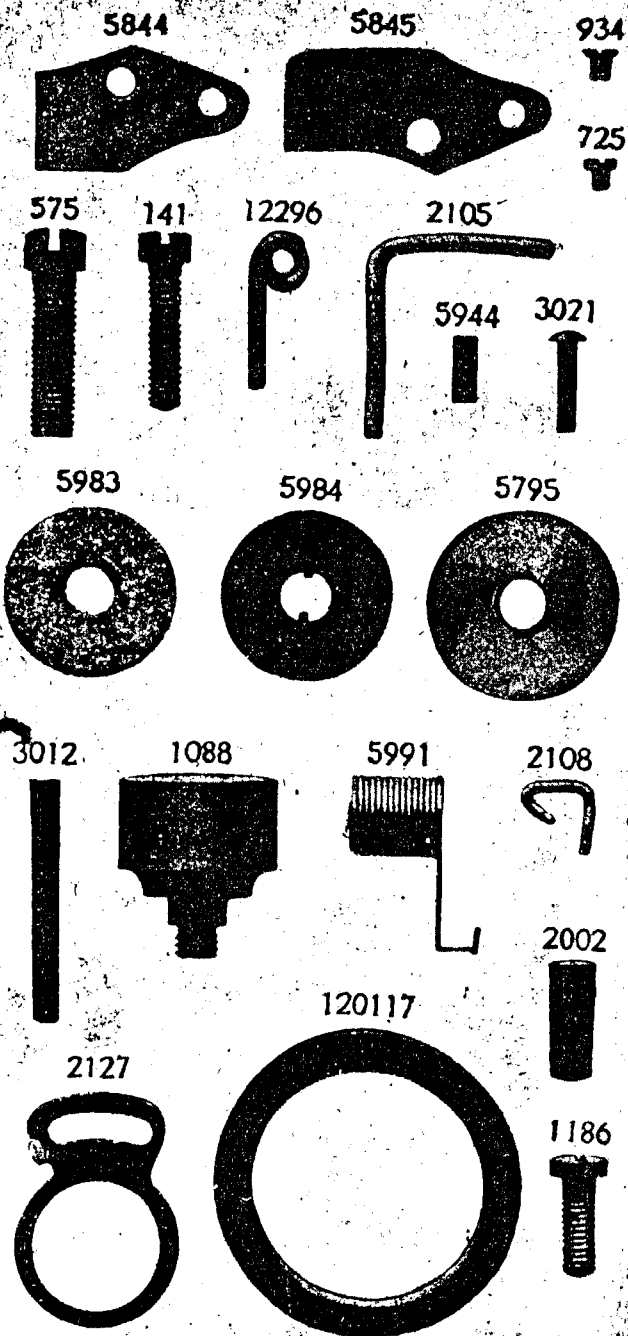


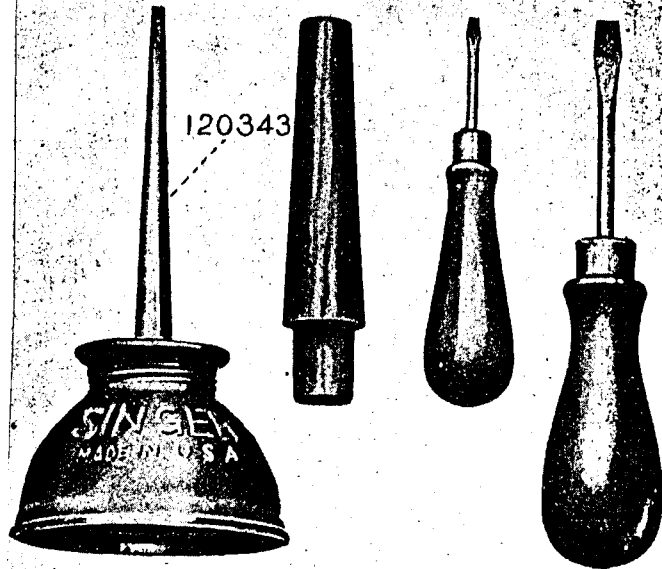
PLATE 3636—FULL SIZE



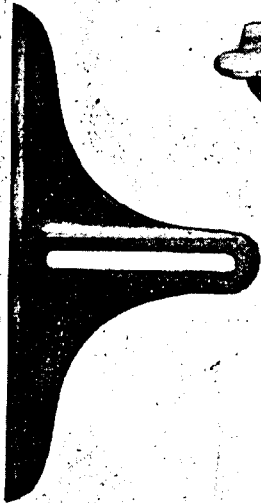
From the library of: Diamond Needle Corp

PLATE 3637—ONE-HALF SIZE

120342 41400 26485 26026



25868



27056



4347



PLATE 3638—ONE-HALF SIZE

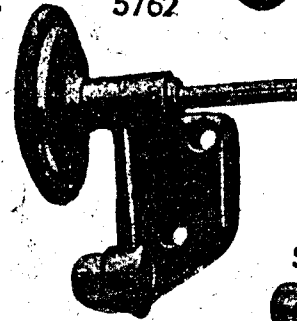
4724 5599 5872 5871



4728



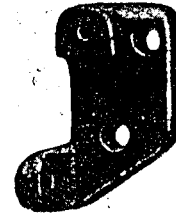
5762



5959



5958



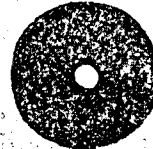
11114



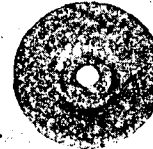
5761



5961



5963



5960

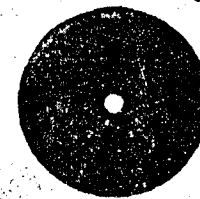


PLATE 3641—FULL SIZE

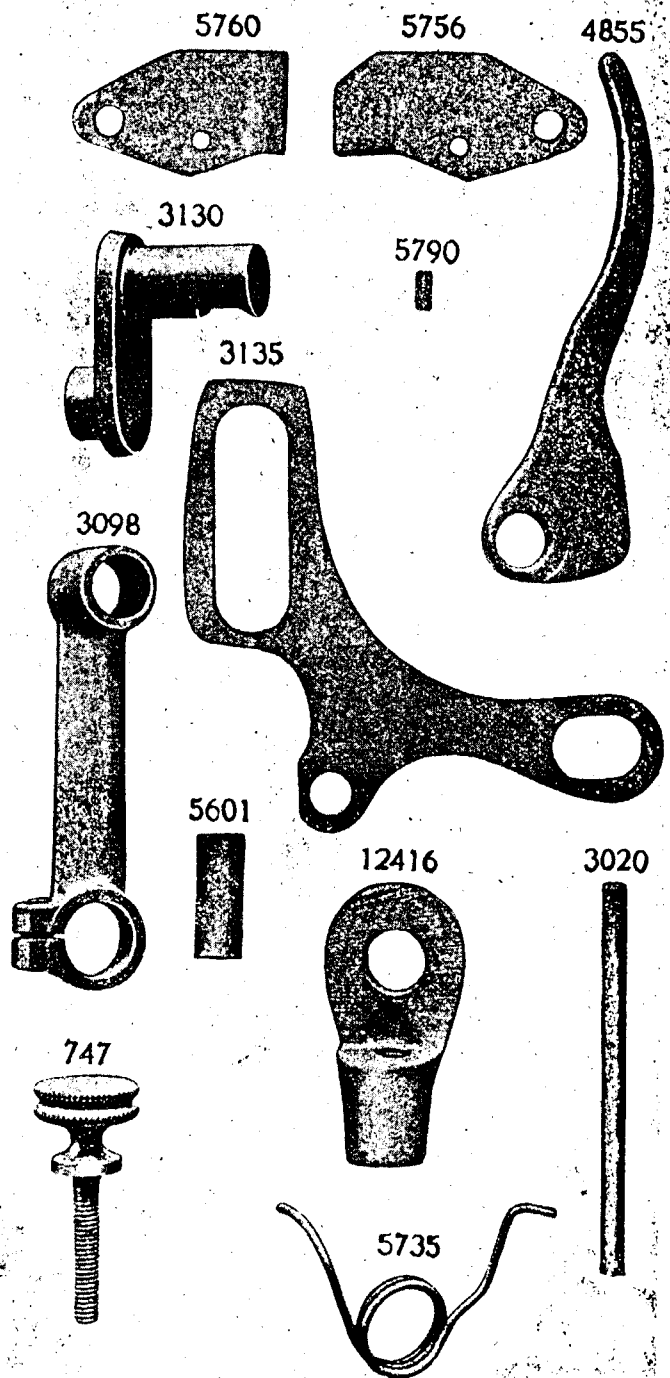


PLATE 3642—ONE-FOURTH SIZE

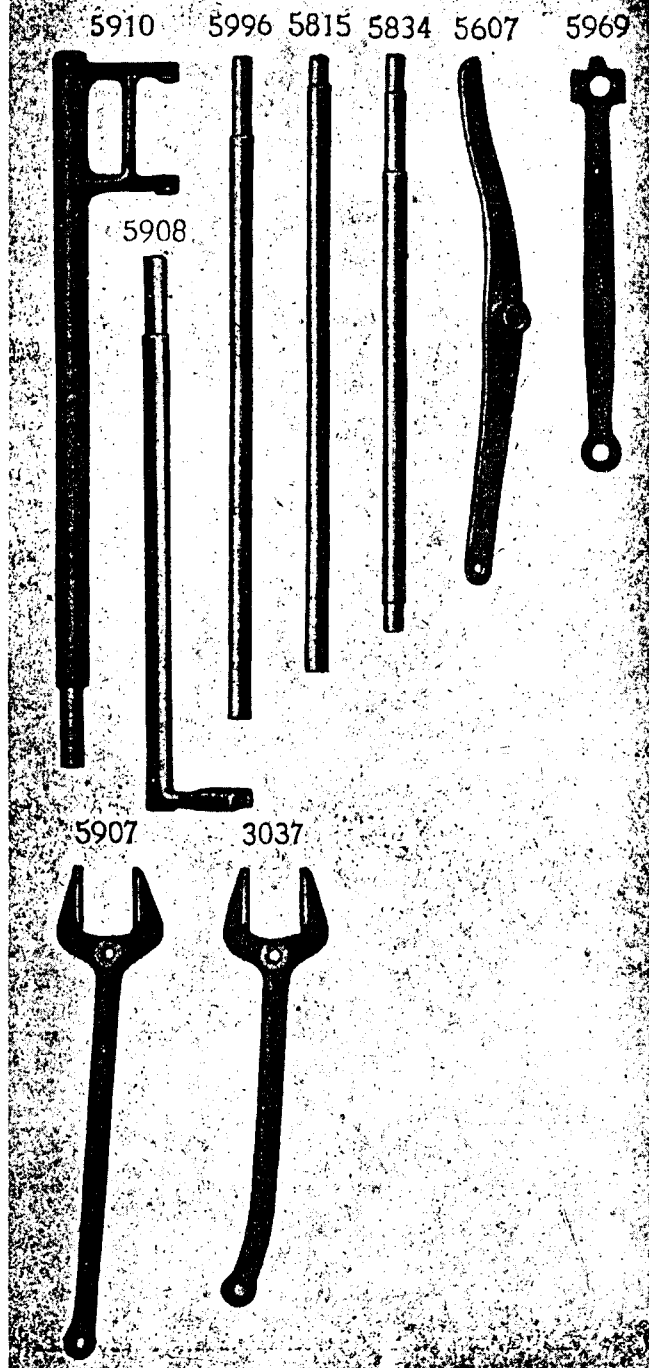


PLATE 3643—FULL SIZE

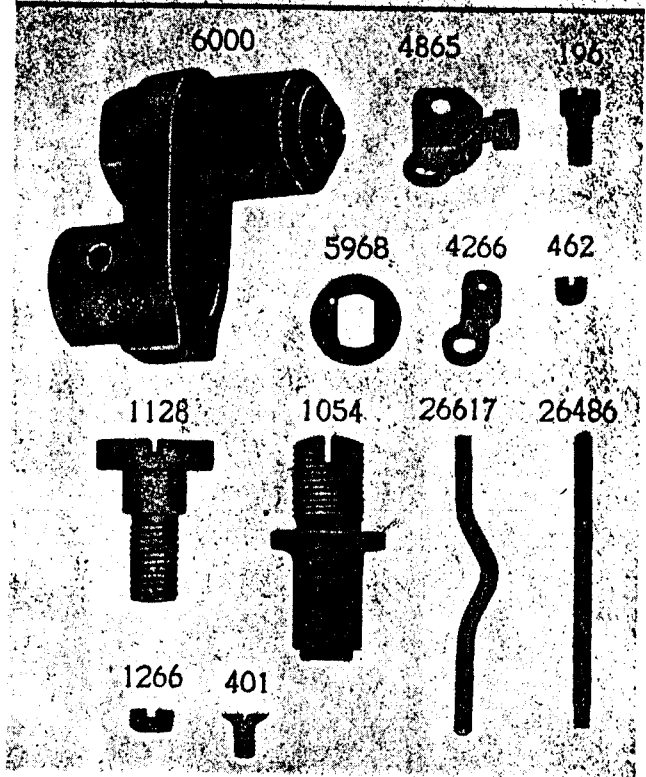
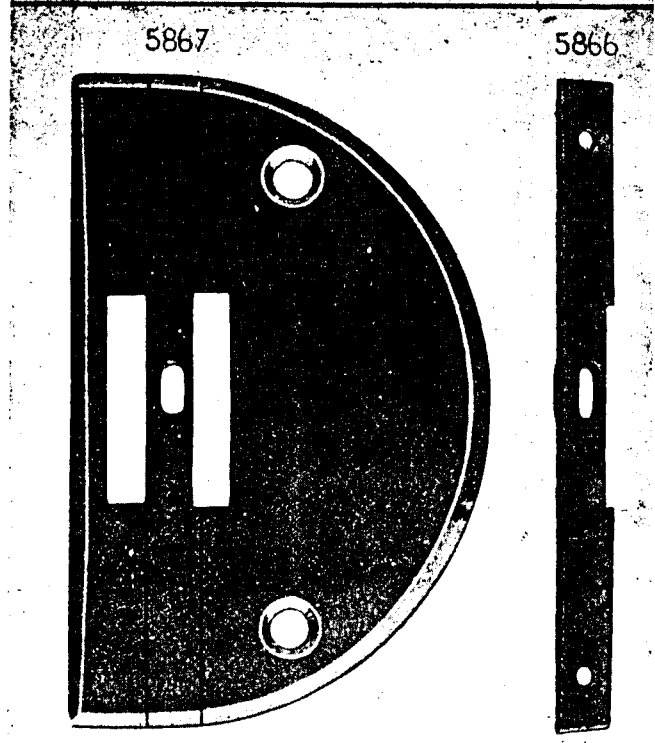


PLATE 3644—FULL SIZE



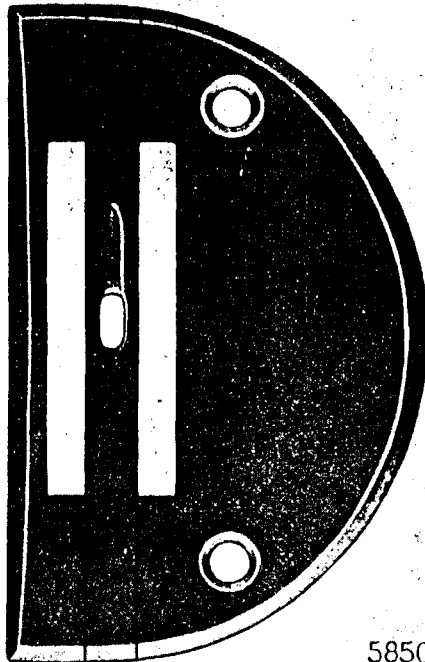
From the library of: Diamond Needle Corp

PLATE 3645—FULL SIZE

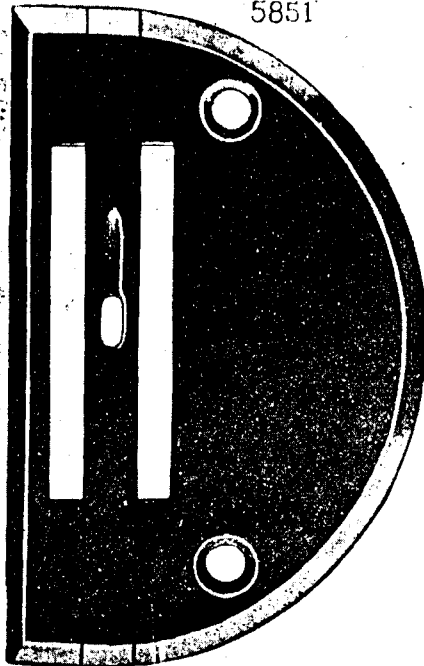
5853



5854



5851



5850



PLATE 3646—FULL SIZE

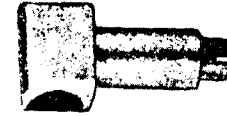
5885



5879



3147



5878



1068



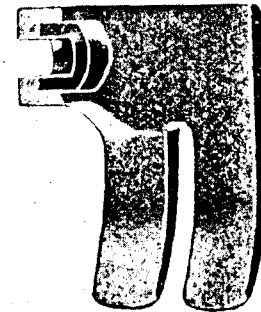
902



2653



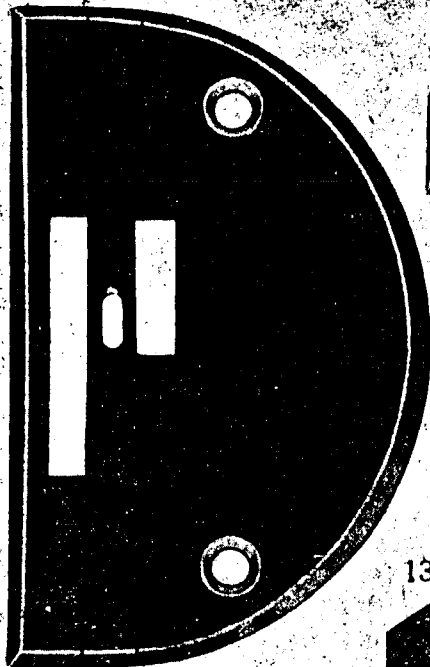
5887



From the library of: Diamond Needle Corp

PLATE 3647—FULL SIZE

8199



8196



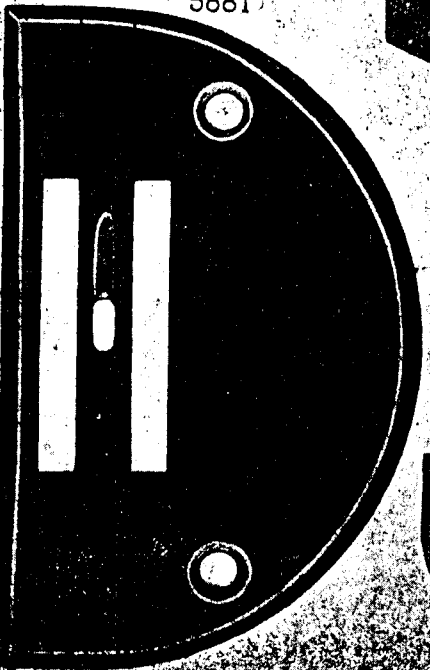
8198



13252



5881

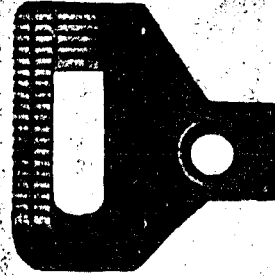


5840

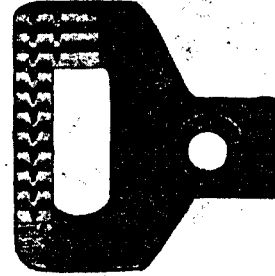


PLATE 3648—FULL SIZE

8157



5888



5889

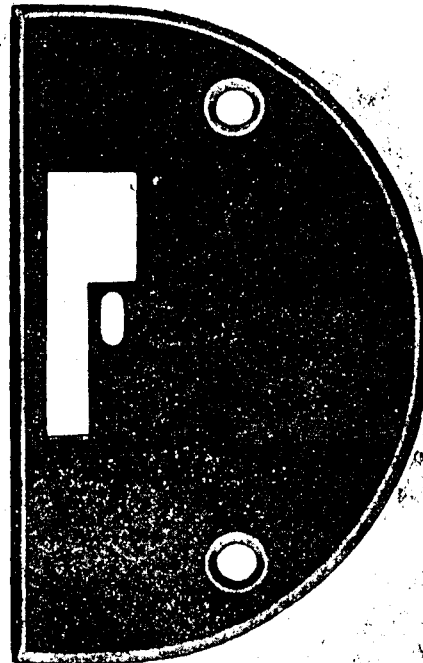
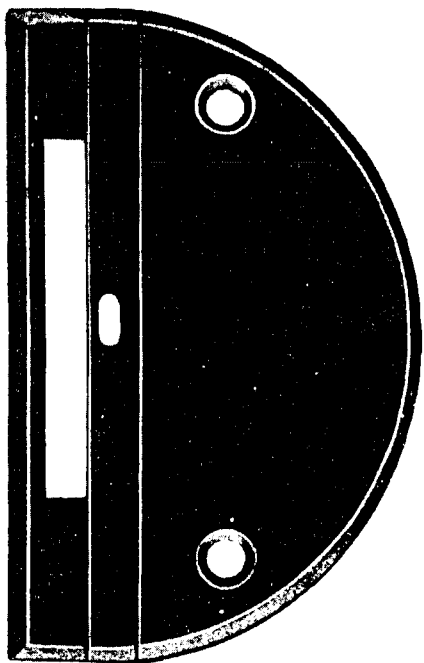


PLATE 3649—FULL SIZE

5898

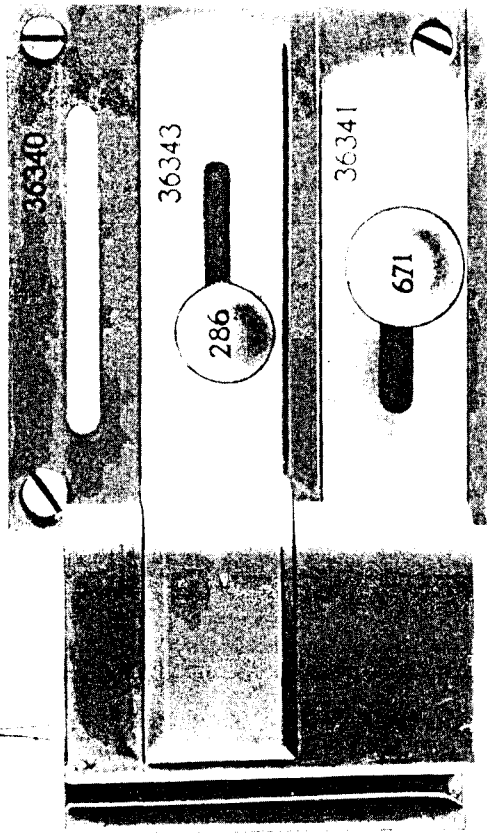


5897



PLATE 5807—FULL SIZE

36344



36340

36343

36341

286

671

36342

From the library of: Diamond Needle Corp

PLATE 7790—FULL SIZE

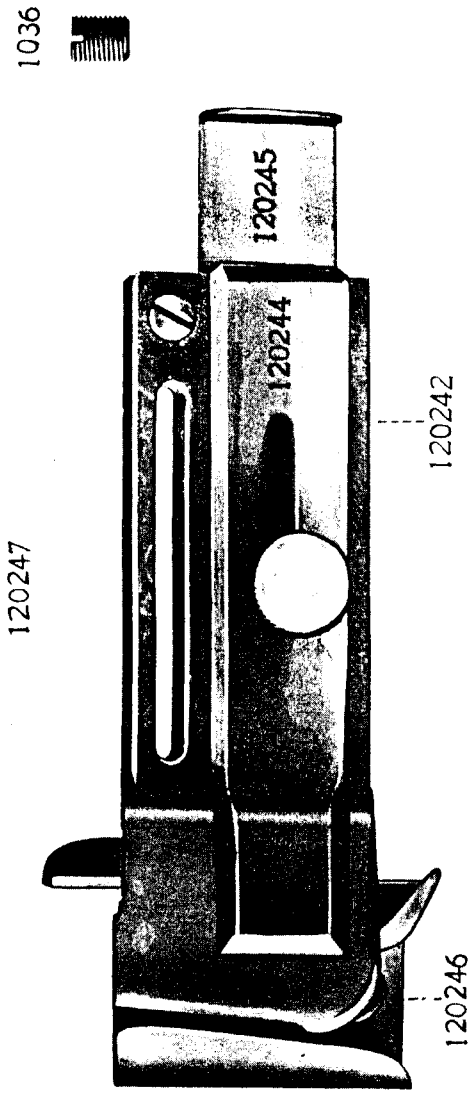
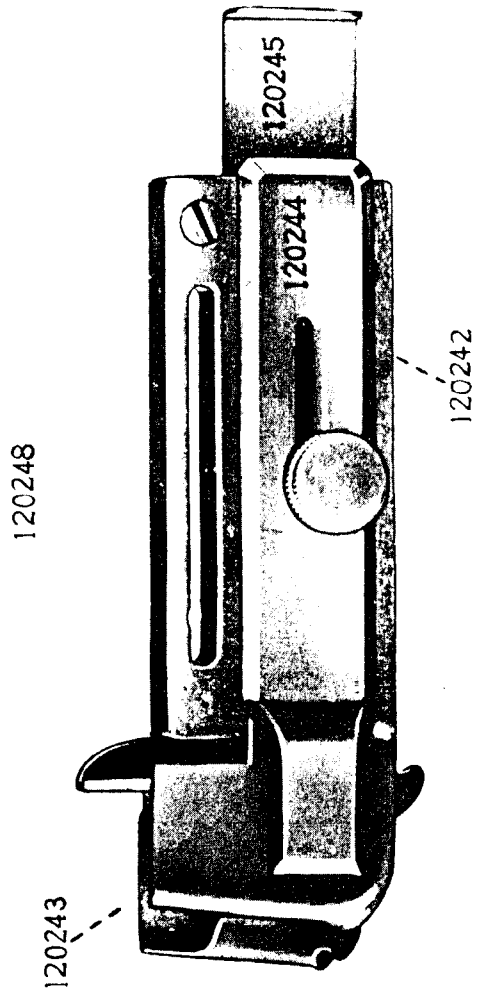


PLATE 7791—FULL SIZE



From the library of: Diamond Needle Corp

PLATE 7792—FULL SIZE

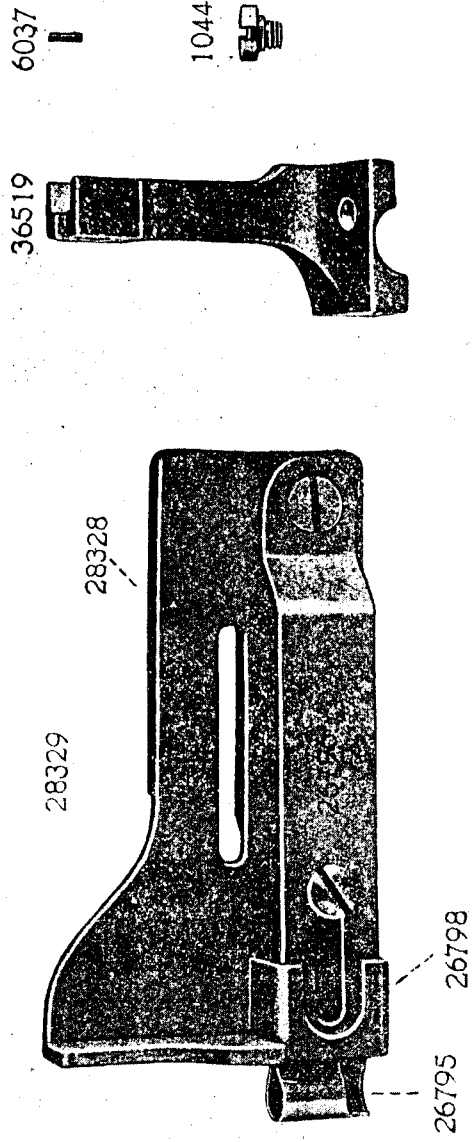
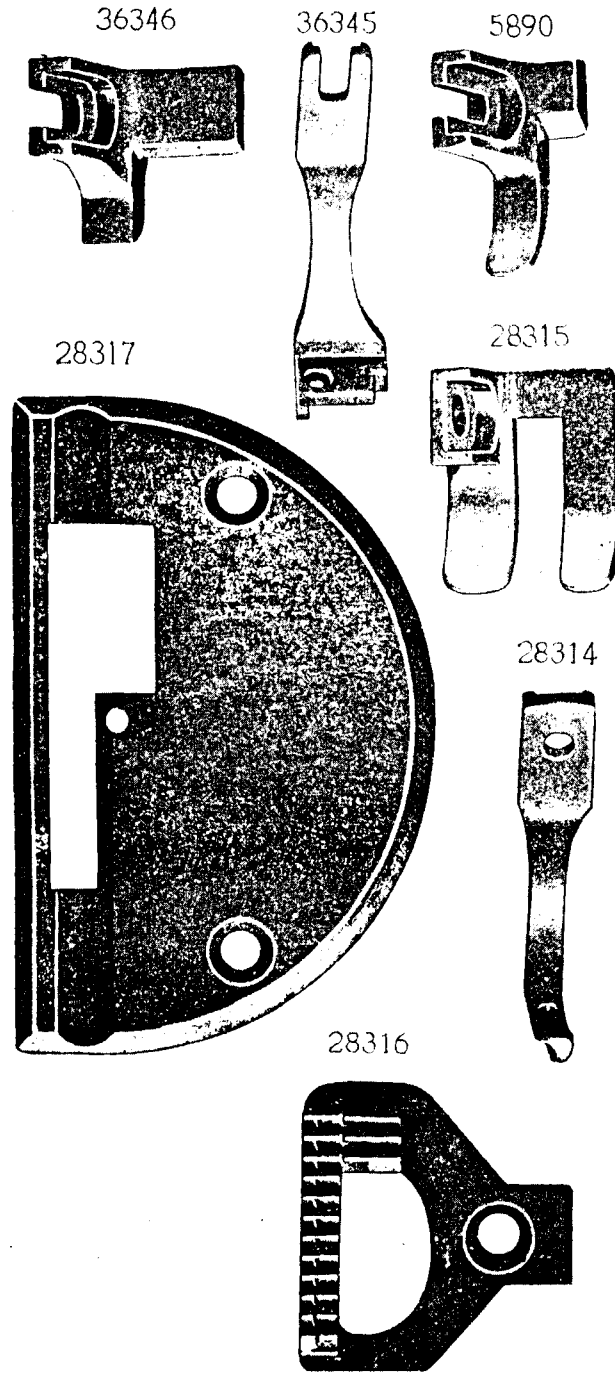


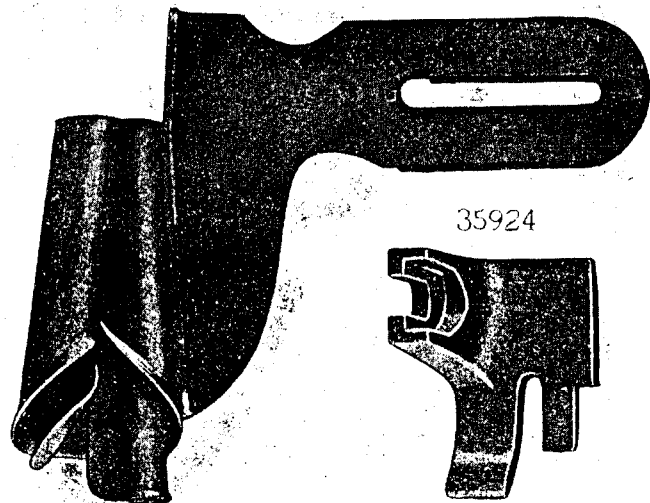
PLATE 7793—FULL SIZE



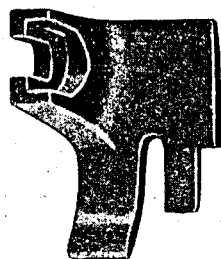
From the library of: Diamond Needle Corp

PLATE 7794—FULL SIZE

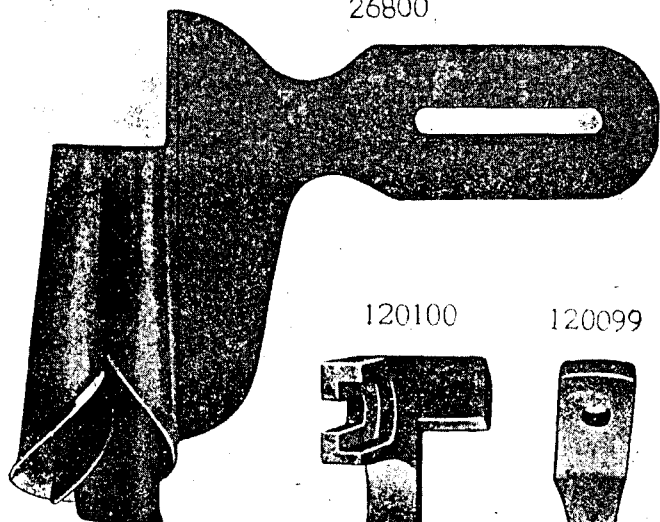
35923



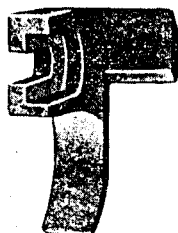
35924



26800



120100

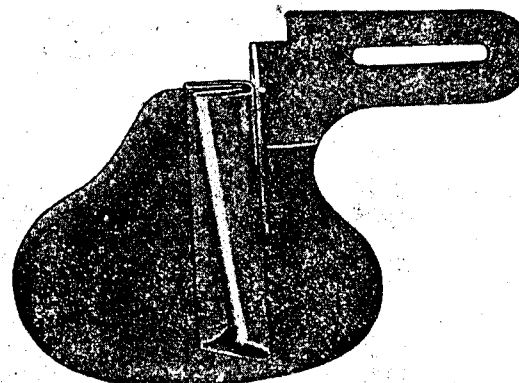


120099

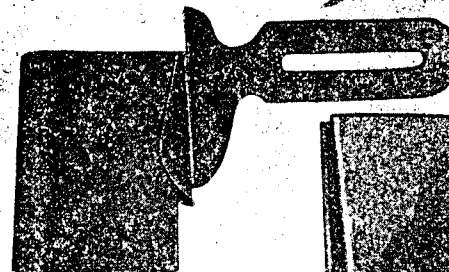


PLATE 7795—ONE-HALF SIZE

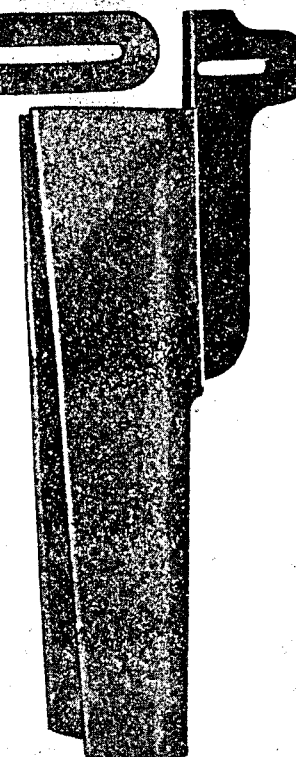
35090



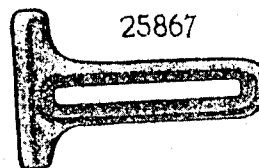
36999



28301



25867



From the library of: Diamond Needle Corp

PLATE 7800—ONE-HALF SIZE

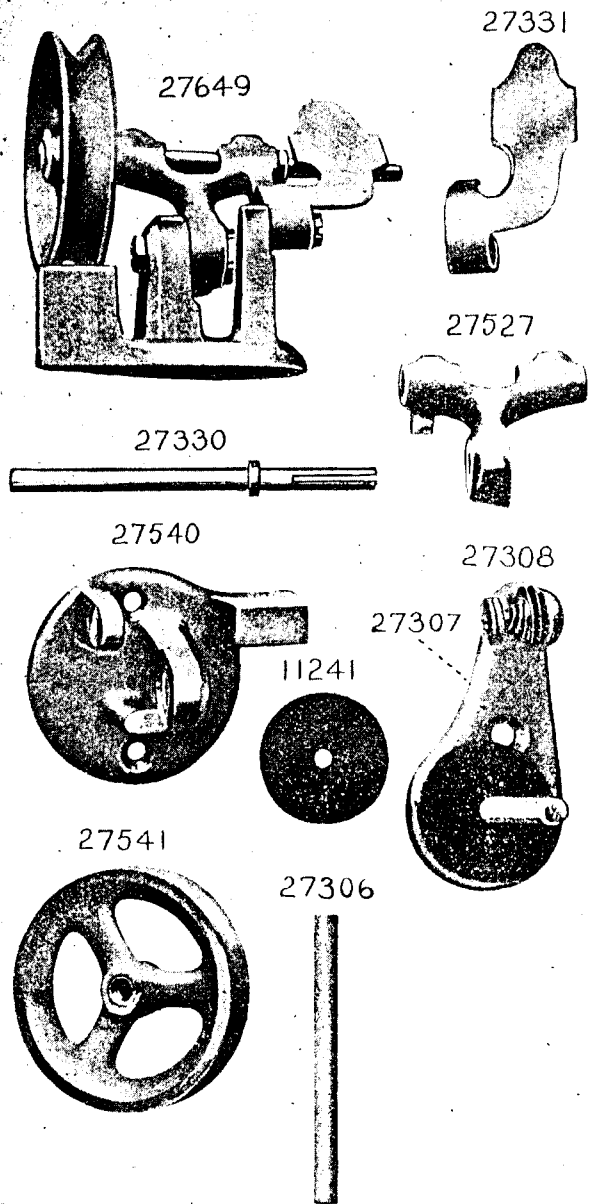
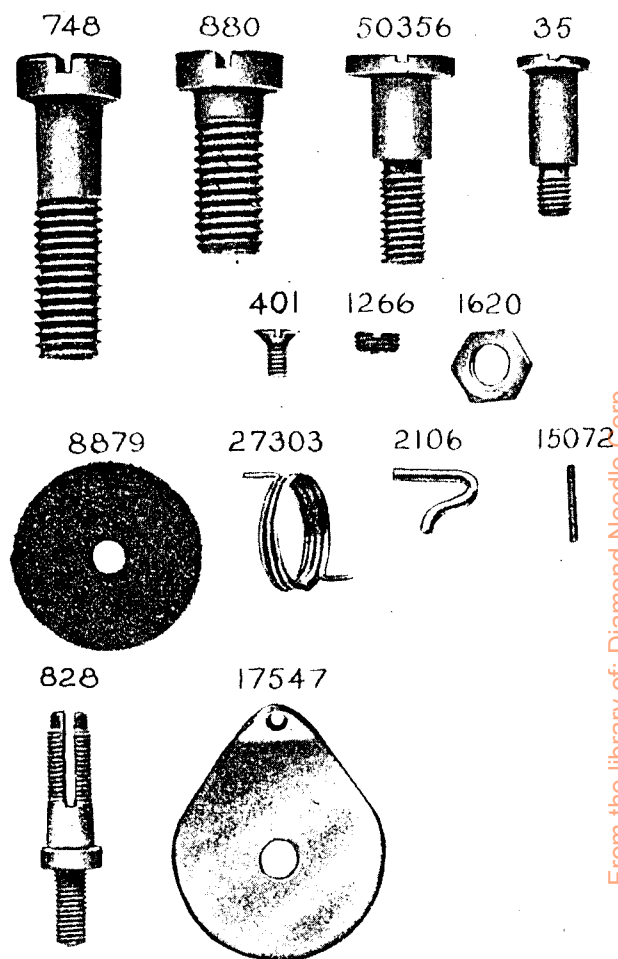


PLATE 7801—FULL SIZE



From the library of: Diamond Needle Corp

PLATE 7802—ONE-NINTH SIZE

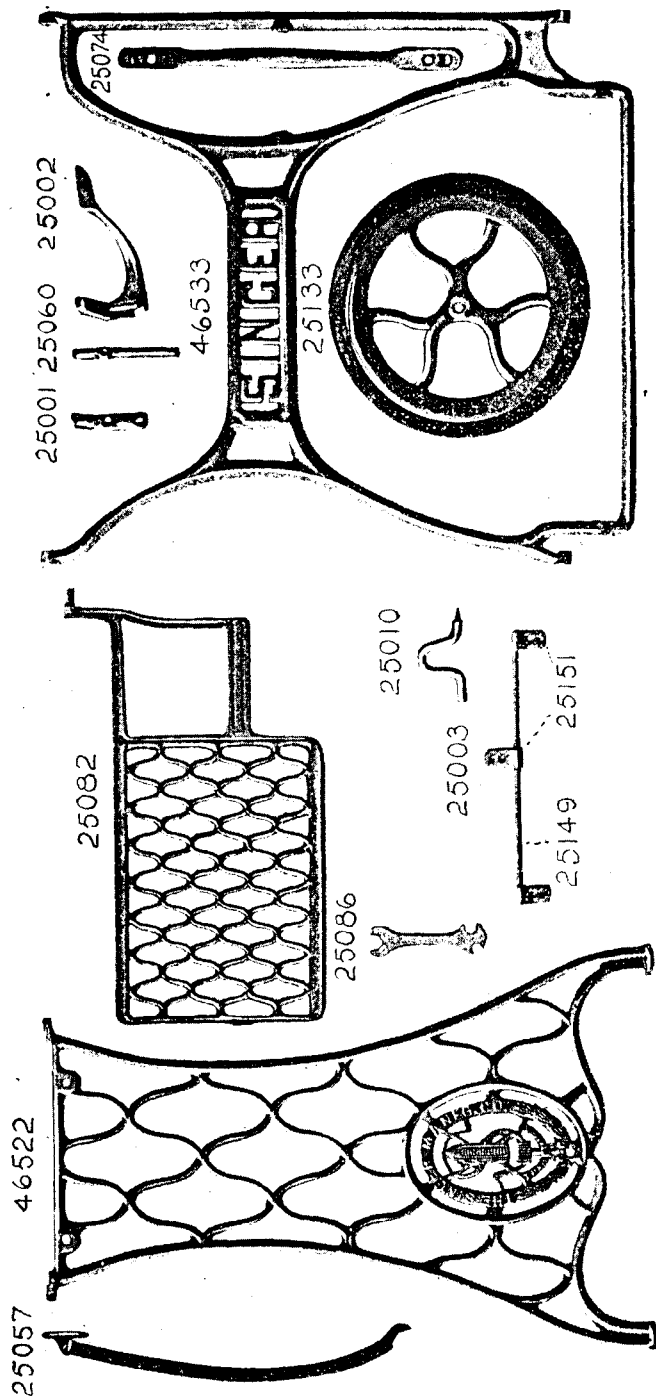
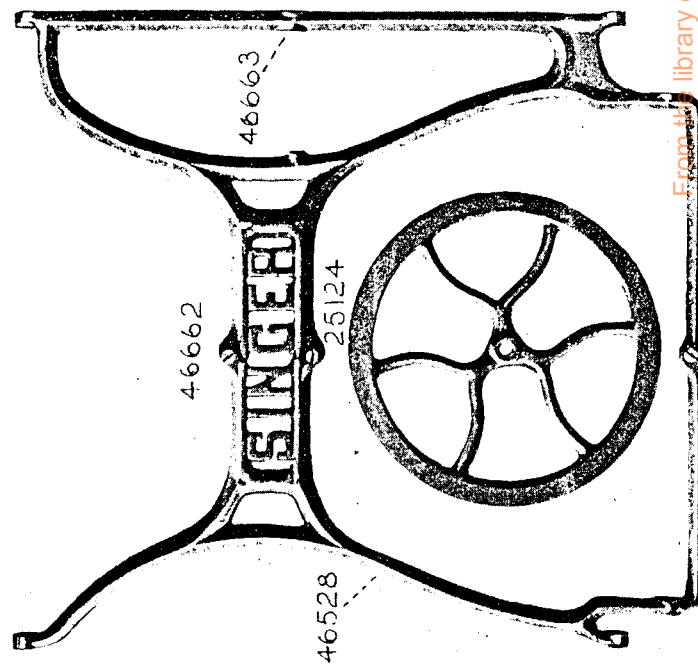
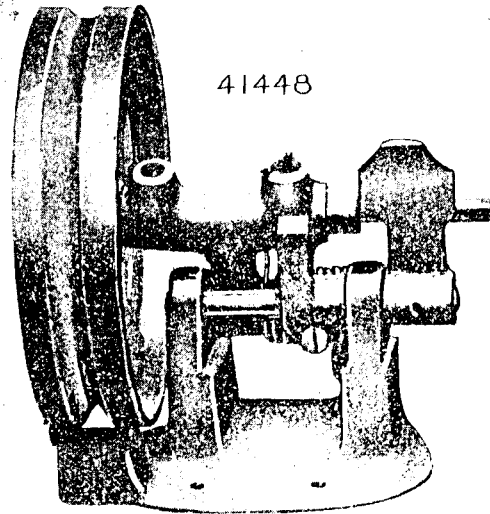


PLATE 7803—ONE-EIGHTH SIZE

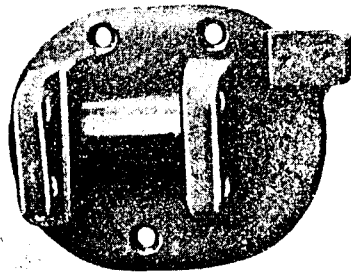


From the library of: Diamond Needle Corp

PLATE 7804--ONE-HALF SIZE



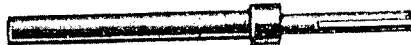
41439



41445



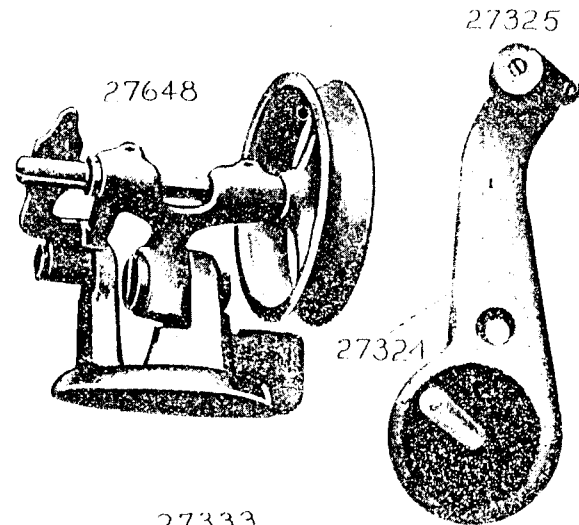
41444



41446



PLATE 7805--ONE-HALF SIZE

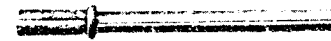


27648

27325

27324

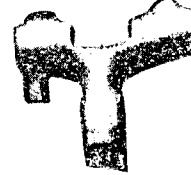
27333



27334



27302



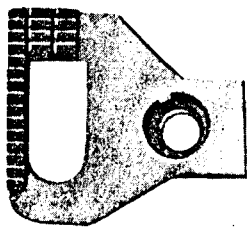
27323



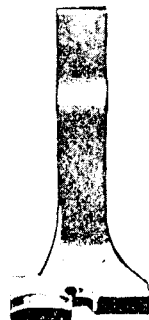
From the library of: Diamond Needle Corp

PLATE 7806—FULL SIZE

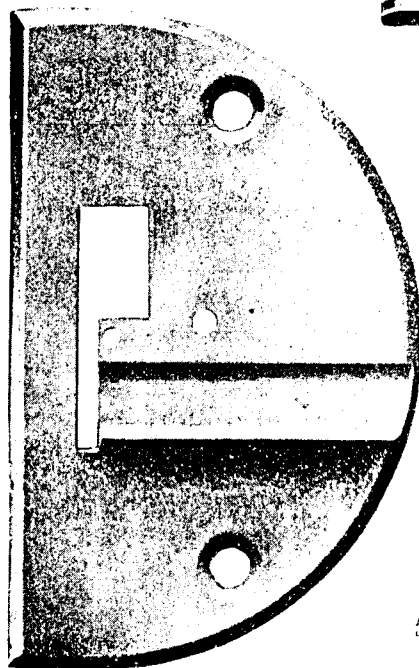
28308



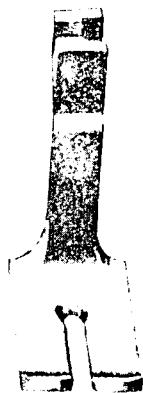
8151



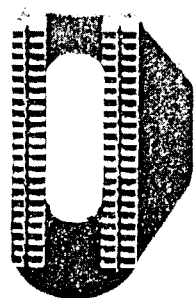
28309



5955



5894



5893

